

CHAPTER 5

FLOORS

SECTION R501 GENERAL

R501.1 Application. The provisions of this chapter shall control the design and construction of the floors for all buildings including the floors of attic spaces used to house mechanical and/or plumbing fixtures and equipment.

R501.2 Requirements. Floor construction shall be capable of accommodating all loads according to Section R301 and of transmitting the resulting loads to the supporting structural elements.

SECTION R502 WOOD FLOOR FRAMING

R502.1 Identification. Load-bearing dimension lumber for joists, beams and girders shall be identified by a grade mark of a lumber grading or inspection agency that has been approved by an accreditation body that complies with DOC PS 20. In lieu of a grade mark, a certificate of inspection issued by a lumber grading or inspection agency meeting the requirements of this section shall be accepted.

R502.1.1 Preservatively treated lumber. Preservatively treated dimension lumber shall also be identified as required by Section R319.1.

R502.1.2 Blocking and subflooring. Blocking shall be a minimum of utility grade lumber. Subflooring may be a minimum of utility grade lumber or No. 4 common grade boards.

R502.1.3 End-jointed lumber. Approved end-jointed lumber identified by a grade mark conforming to Section R501.2 may be used interchangeably with solid-sawn members of the same species and grade.

R502.1.4 Prefabricated wood I-joists. Structural capacities and design provisions for prefabricated wood I-joists shall be established and monitored in accordance with ASTM D 5055.

R502.1.5 Structural glued laminated timbers. Glued laminated timbers shall be manufactured and identified as required in AITC A190.1 and ASTM D3737.

R502.2 Design and construction. Floors shall be designed and constructed in accordance with the provisions of this chapter, Figure R502.2 and Sections R319 and R320 or in accordance with AF&PA/NDS.

R502.2.1 Decks. Where supported by attachment to an exterior wall, decks shall be positively anchored to the primary structure and designed for both vertical and lateral loads as applicable. Such attachment shall not be accomplished by

the use of toenails or nails subject to withdrawal. Where positive connection to the primary building structure cannot be verified during inspection, decks shall be self-supporting. For decks with cantilevered framing members, connections to exterior walls or other framing members, shall be designed and constructed to resist uplift resulting from the full live load specified in Table R301.5 acting on the cantilevered portion of the deck. Exterior decks shall be permitted to be constructed in accordance with Appendix M.

R502.3 Allowable joist spans. Spans for floor joists shall be in accordance with Tables R502.3.1(1) and R502.3.1(2). For other grades and species and for other loading conditions, refer to the AF&PA Span Tables for Joists and Rafters.

R502.3.1 Sleeping areas and attic joists. Table R502.3.1(1) shall be utilized to determine the maximum allowable span of floor joists that support sleeping areas and attics that are accessed by means of a fixed stairway provided that the design live load does not exceed 30 psf (1.44 kN/m²) and the design dead load does not exceed 10 psf (0.48 kN/m²). The allowable span of ceiling joists that support attics utilized for limited storage or no storage shall be determined in accordance with Section R802.4.

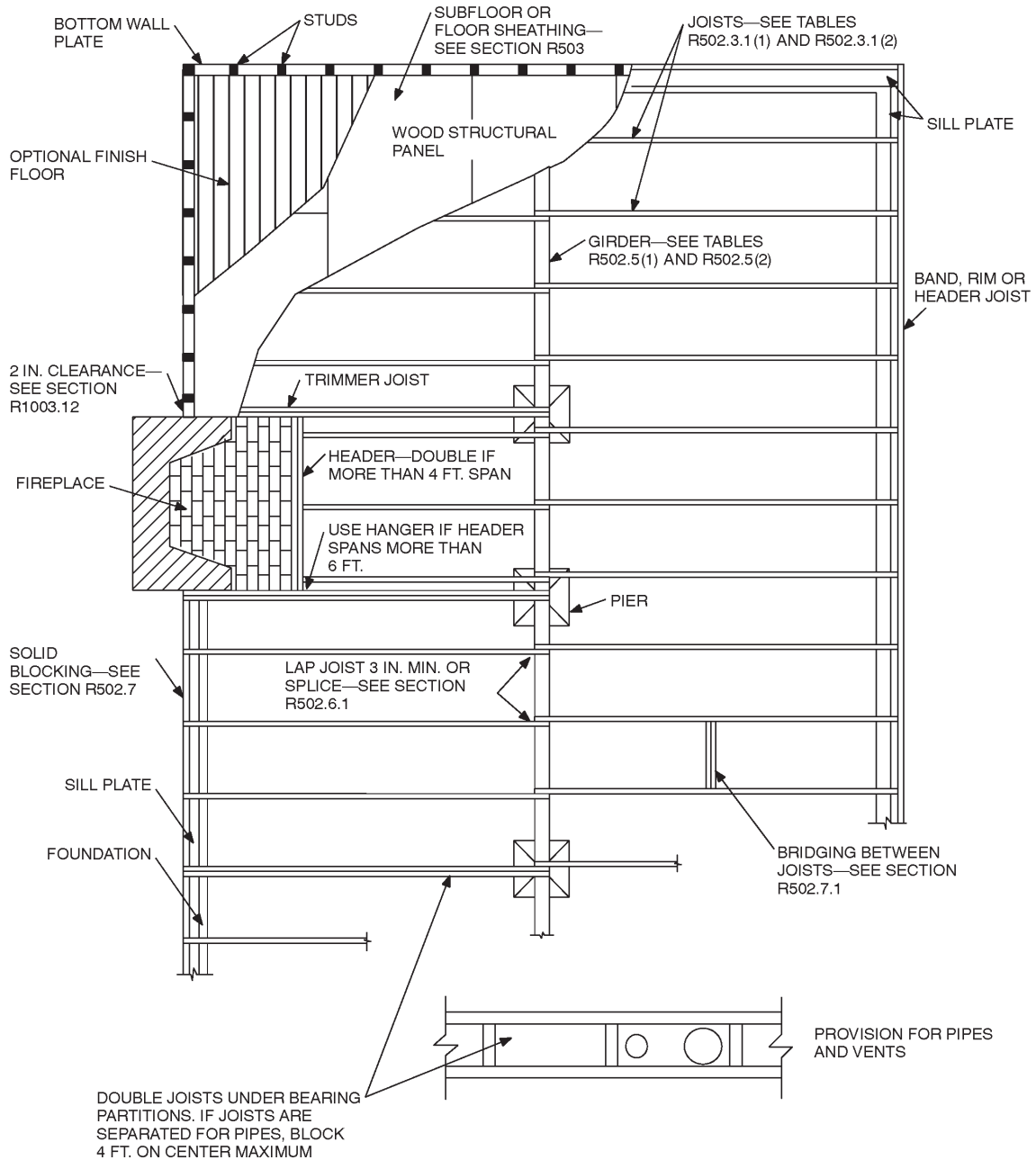
R502.3.2 Other floor joists. Table R502.3.1(2) shall be utilized to determine the maximum allowable span of floor joists that support all areas of the building, other than sleeping and attics, provided that the design live load does not exceed 40 psf (1.92 kN/m²) and the design dead does not exceed 10 psf (0.48 kN/m²).

R502.3.3 Floor cantilevers. Floor cantilever spans shall not exceed the nominal depth of the wood floor joist. Floor cantilevers constructed in accordance with Table R502.3.3(1) shall be permitted when supporting a light-frame bearing wall and roof only. Floor cantilevers supporting an exterior balcony are permitted to be constructed in accordance with Table R502.3.3(2).

R502.4 Joists under bearing partitions. Joists under parallel bearing partitions shall be of adequate size to support the load. Double joists, sized to adequately support the load, that are separated to permit the installation of piping or vents shall be full depth solid blocked with lumber not less than 2 inches (51 mm) in nominal thickness spaced not more than 4 feet (1219 mm) on center. Bearing partitions perpendicular to joists shall not be offset from supporting girders, walls or partitions more than the joist depth unless such joists are of sufficient size to carry the additional load.

R502.5 Allowable girder spans. The allowable spans of girders fabricated of dimension lumber shall not exceed the values set forth in Tables R502.5(1) and R502.5(2).

FLOORS



For SI: 1 inch = 25.4 mm, 1 foot = 304.8 mm.

FIGURE R502.2
FLOOR CONSTRUCTION

TABLE R502.3.1(1)
FLOOR JOIST SPANS FOR COMMON LUMBER SPECIES
(Residential sleeping areas, live load = 30 psf, L/Δ = 360)

JOIST SPACING (inches)	SPECIES AND GRADE		DEAD LOAD = 10 psf				DEAD LOAD = 20 psf			
			2x6	2x8	2x10	2x12	2x6	2x8	2x10	2x12
			Maximum floor joist spans							
			(ft.- in.)	(ft.- in.)	(ft.- in.)	(ft.- in.)	(ft.- in.)	(ft.- in.)	(ft.- in.)	(ft.- in.)
12	Douglas fir-larch	SS	12- 6	16- 6	21- 0	25- 7	12- 6	16- 6	21- 0	25- 7
	Douglas fir-larch	#1	12- 0	15-10	20- 3	24- 8	12- 0	15- 7	19- 0	22- 0
	Douglas fir-larch	#2	11-10	15- 7	19-10	23- 0	11- 6	14- 7	17- 9	20- 7
	Douglas fir-larch	#3	9- 8	12- 4	15- 0	17- 5	8- 8	11- 0	13- 5	15- 7
	Hem-fir	SS	11-10	15- 7	19-10	24- 2	11-10	15- 7	19-10	24- 2
	Hem-fir	#1	11- 7	15- 3	19- 5	23- 7	11- 7	15- 2	18- 6	21- 6
	Hem-fir	#2	11- 0	14- 6	18- 6	22- 6	11- 0	14- 4	17- 6	20- 4
	Hem-fir	#3	9- 8	12- 4	15- 0	17- 5	8- 8	11- 0	13- 5	15- 7
	Southern pine	SS	12- 3	16- 2	20- 8	25- 1	12- 3	16- 2	20- 8	25- 1
	Southern pine	#1	12- 0	15-10	20- 3	24- 8	12- 0	15-10	20- 3	24- 8
	Southern pine	#2	11-10	15- 7	19-10	24- 2	11-10	15- 7	18- 7	21- 9
	Southern pine	#3	10- 5	13- 3	15- 8	18- 8	9- 4	11-11	14- 0	16- 8
	Spruce-pine-fir	SS	11- 7	15- 3	19- 5	23- 7	11- 7	15- 3	19- 5	23- 7
	Spruce-pine-fir	#1	11- 3	14-11	19- 0	23- 0	11- 3	14- 7	17- 9	20- 7
	Spruce-pine-fir	#2	11- 3	14-11	19- 0	23- 0	11- 3	14- 7	17- 9	20- 7
	Spruce-pine-fir	#3	9- 8	12- 4	15- 0	17- 5	8- 8	11- 0	13- 5	15- 7
16	Douglas fir-larch	SS	11- 4	15- 0	19- 1	23- 3	11- 4	15- 0	19- 1	23- 0
	Douglas fir-larch	#1	10-11	14- 5	18- 5	21- 4	10- 8	13- 6	16- 5	19- 1
	Douglas fir-larch	#2	10- 9	14- 1	17- 2	19-11	9-11	12- 7	15- 5	17-10
	Douglas fir-larch	#3	8- 5	10- 8	13- 0	15- 1	7- 6	9- 6	11- 8	13- 6
	Hem-fir	SS	10- 9	14- 2	18- 0	21-11	10- 9	14- 2	18- 0	21-11
	Hem-fir	#1	10- 6	13-10	17- 8	20- 9	10- 4	13- 1	16- 0	18- 7
	Hem-fir	#2	10- 0	13- 2	16-10	19- 8	9-10	12- 5	15- 2	17- 7
	Hem-fir	#3	8- 5	10- 8	13- 0	15- 1	7- 6	9- 6	11- 8	13- 6
	Southern pine	SS	11- 2	14- 8	18- 9	22-10	11- 2	14- 8	18- 9	22-10
	Southern pine	#1	10-11	14- 5	18- 5	22- 5	10-11	14- 5	17-11	21- 4
	Southern pine	#2	10- 9	14- 2	18- 0	21- 1	10- 5	13- 6	16- 1	18-10
	Southern pine	#3	9- 0	11- 6	13- 7	16- 2	8- 1	10- 3	12- 2	14- 6
	Spruce-pine-fir	SS	10- 6	13-10	17- 8	21- 6	10- 6	13-10	17- 8	21- 4
	Spruce-pine-fir	#1	10- 3	13- 6	17- 2	19-11	9-11	12- 7	15- 5	17-10
	Spruce-pine-fir	#2	10- 3	13- 6	17- 2	19-11	9-11	12- 7	15- 5	17-10
	Spruce-pine-fir	#3	8- 5	10- 8	13- 0	15- 1	7- 6	9- 6	11- 8	13- 6
19.2	Douglas fir-larch	SS	10- 8	14- 1	18- 0	21-10	10- 8	14- 1	18- 0	21- 0
	Douglas fir-larch	#1	10- 4	13- 7	16- 9	19- 6	9- 8	12- 4	15- 0	17- 5
	Douglas fir-larch	#2	10- 1	12-10	15- 8	18- 3	9- 1	11- 6	14- 1	16- 3
	Douglas fir-larch	#3	7- 8	9- 9	11-10	13- 9	6-10	8- 8	10- 7	12- 4
	Hem-fir	SS	10- 1	13- 4	17- 0	20- 8	10- 1	13- 4	17- 0	20- 7
	Hem-fir	#1	9-10	13- 0	16- 4	19- 0	9- 6	12- 0	14- 8	17- 0
	Hem-fir	#2	9- 5	12- 5	15- 6	17- 1	8-11	11- 4	13-10	16- 1
	Hem-fir	#3	7- 8	9- 9	11- 10	13- 9	6-10	8- 8	10- 7	12- 4
	Southern pine	SS	10- 6	13-10	17- 8	21- 6	10- 6	13-10	17- 8	21- 6
	Southern pine	#1	10- 4	13- 7	17- 4	21- 1	10- 4	13- 7	16- 4	19- 6
	Southern pine	#2	10- 1	13- 4	16- 5	19- 3	9- 6	12- 4	14- 8	17- 2
	Southern pine	#3	8- 3	10- 6	12- 5	14- 9	7- 4	9- 5	11- 1	13- 2
	Spruce-pine-fir	SS	9- 10	13- 0	16- 7	20- 2	9-10	13- 0	16- 7	19- 6
	Spruce-pine-fir	#1	9- 8	12- 9	15- 8	18- 3	9- 1	11- 6	14- 1	16- 3
	Spruce-pine-fir	#2	9- 8	12- 9	15- 8	18- 3	9- 1	11- 6	14- 1	16- 3
	Spruce-pine-fir	#3	7- 8	9- 9	11-10	13- 9	6-10	8- 8	10- 7	12- 4
24	Douglas fir-larch	SS	9-11	13- 1	16- 8	20- 3	9-11	13- 1	16- 2	18- 9
	Douglas fir-larch	#1	9- 7	12- 4	15- 0	17- 5	8- 8	11- 0	13- 5	15- 7
	Douglas fir-larch	#2	9- 1	11- 6	14- 1	16- 3	8- 1	10- 3	12- 7	14- 7
	Douglas fir-larch	#3	6-10	8- 8	10- 7	12- 4	6- 2	7- 9	9- 6	11- 0
	Hem-fir	SS	9- 4	12- 4	15- 9	19- 2	9- 4	12- 4	15- 9	18- 5
	Hem-fir	#1	9- 2	12- 0	14- 8	17- 0	8- 6	10- 9	13- 1	15- 2
	Hem-fir	#2	8- 9	11- 4	13-10	16- 1	8- 0	10- 2	12- 5	14- 4
	Hem-fir	#3	6-10	8- 8	10- 7	12- 4	6- 2	7- 9	9- 6	11- 0
	Southern pine	SS	9- 9	12-10	16- 5	19-11	9- 9	12-10	16- 5	19-11
	Southern pine	#1	9- 7	12- 7	16- 1	19- 6	9- 7	12- 4	14- 7	17- 5
	Southern pine	#2	9- 4	12- 4	14- 8	17- 2	8- 6	11- 0	13- 1	15- 5
	Southern pine	#3	7- 4	9- 5	11- 1	13- 2	6- 7	8- 5	9-11	11-10
	Spruce-pine-fir	SS	9- 2	12- 1	15- 5	18- 9	9- 2	12- 1	15- 0	17- 5
	Spruce-pine-fir	#1	8-11	11- 6	14- 1	16- 3	8- 1	10- 3	12- 7	14- 7
	Spruce-pine-fir	#2	8-11	11- 6	14- 1	16- 3	8- 1	10- 3	12- 7	14- 7
	Spruce-pine-fir	#3	6-10	8- 8	10- 7	12- 4	6- 2	7- 9	9- 6	11- 0

For SI: 1 inch = 25.4 mm, 1 foot = 304.8 mm, 1 pound per square foot = 0.0479kN/m².

NOTE: Check sources for availability of lumber in lengths greater than 20 feet.

FLOORS

TABLE R502.3.1(2)
FLOOR JOIST SPANS FOR COMMON LUMBER SPECIES
 (Residential living areas, live load = 40 psf, L/Δ = 360)

JOIST SPACING (inches)	SPECIES AND GRADE	DEAD LOAD = 10 psf				DEAD LOAD = 20 psf			
		2x6	2x8	2x10	2x12	2x6	2x8	2x10	2x12
		Maximum floor joist spans							
		(ft.- in.)	(ft.- in.)	(ft.- in.)	(ft.- in.)	(ft.- in.)	(ft.- in.)	(ft.- in.)	(ft.- in.)
12	Douglas fir-larch SS	11- 4	15- 0	19- 1	23- 3	11- 4	15- 0	19- 1	23- 3
	Douglas fir-larch #1	10-11	14- 5	18- 5	22- 0	10-11	14- 2	17- 4	20- 1
	Douglas fir-larch #2	10- 9	14- 2	17- 9	20- 7	10- 6	13- 3	16- 3	18-10
	Douglas fir-larch #3	8- 8	11- 0	13- 5	15- 7	7-11	10- 0	12- 3	14- 3
	Hem-fir SS	10- 9	14- 2	18- 0	21-11	10- 9	14- 2	18- 0	21-11
	Hem-fir #1	10- 6	13-10	17- 8	21- 6	10- 6	13-10	16-11	19- 7
	Hem-fir #2	10- 0	13- 2	16-10	20- 4	10- 0	13- 1	16- 0	18- 6
	Hem-fir #3	8- 8	11- 0	13- 5	15- 7	7-11	10- 0	12- 3	14- 3
	Southern pine SS	11- 2	14- 8	18- 9	22-10	11- 2	14- 8	18- 9	22-10
	Southern pine #1	10-11	14- 5	18- 5	22- 5	10-11	14- 5	18- 5	22- 5
	Southern pine #2	10- 9	14- 2	18- 0	21- 9	10- 9	14- 2	16-11	19-10
	Southern pine #3	9- 4	11-11	14- 0	16- 8	8- 6	10-10	12-10	15- 3
	Spruce-pine-fir SS	10- 6	13-10	17- 8	21- 6	10- 6	13-10	17- 8	21- 6
	Spruce-pine-fir #1	10- 3	13- 6	17- 3	20- 7	10- 3	13- 3	16- 3	18-10
	Spruce-pine-fir #2	10- 3	13- 6	17- 3	20- 7	10- 3	13- 3	16- 3	18-10
	Spruce-pine-fir #3	8- 8	11- 0	13- 5	15- 7	7-11	10- 0	12- 3	14- 3
16	Douglas fir-larch SS	10- 4	13- 7	17- 4	21- 1	10- 4	13- 7	17- 4	21- 0
	Douglas fir-larch #1	9-11	13- 1	16- 5	19- 1	9- 8	12- 4	15- 0	17- 5
	Douglas fir-larch #2	9- 9	12- 7	15- 5	17-10	9- 1	11- 6	14- 1	16- 3
	Douglas fir-larch #3	7- 6	9- 6	11- 8	13- 6	6-10	8- 8	10- 7	12- 4
	Hem-fir SS	9- 9	12-10	16- 5	19-11	9- 9	12-10	16- 5	19-11
	Hem-fir #1	9- 6	12- 7	16- 0	18- 7	9- 6	12- 0	14- 8	17- 0
	Hem-fir #2	9- 1	12- 0	15- 2	17- 7	8-11	11- 4	13-10	16- 1
	Hem-fir #3	7- 6	9- 6	11- 8	13- 6	6-10	8- 8	10- 7	12- 4
	Southern pine SS	10- 2	13- 4	17- 0	20- 9	10- 2	13- 4	17- 0	20- 9
	Southern pine #1	9-11	13- 1	16- 9	20- 4	9-11	13- 1	16- 4	19- 6
	Southern pine #2	9- 9	12-10	16- 1	18-10	9- 6	12- 4	14- 8	17- 2
	Southern pine #3	8- 1	10- 3	12- 2	14- 6	7- 4	9- 5	11- 1	13- 2
	Spruce-pine-fir SS	9- 6	12- 7	16- 0	19- 6	9- 6	12- 7	16- 0	19- 6
	Spruce-pine-fir #1	9- 4	12- 3	15- 5	17-10	9- 1	11- 6	14- 1	16- 3
	Spruce-pine-fir #2	9- 4	12- 3	15- 5	17-10	9- 1	11- 6	14- 1	16- 3
	Spruce-pine-fir #3	7- 6	9- 6	11- 8	13- 6	6-10	8- 8	10- 7	12- 4
19.2	Douglas fir-larch SS	9- 8	12-10	16- 4	19-10	9- 8	12-10	16- 4	19- 2
	Douglas fir-larch #1	9- 4	12- 4	15- 0	17- 5	8-10	11- 3	13- 8	15-11
	Douglas fir-larch #2	9- 1	11- 6	14- 1	16- 3	8- 3	10- 6	12-10	14-10
	Douglas fir-larch #3	6-10	8- 8	10- 7	12- 4	6- 3	7-11	9- 8	11- 3
	Hem-fir SS	9- 2	12- 1	15- 5	18- 9	9- 2	12- 1	15- 5	18- 9
	Hem-fir #1	9- 0	11-10	14- 8	17- 0	8- 8	10-11	13- 4	15- 6
	Hem-fir #2	8- 7	11- 3	13-10	16- 1	8- 2	10- 4	12- 8	14- 8
	Hem-fir #3	6-10	8- 8	10- 7	12- 4	6- 3	7-11	9- 8	11- 3
	Southern pine SS	9- 6	12- 7	16- 0	19- 6	9- 6	12- 7	16- 0	19- 6
	Southern pine #1	9- 4	12- 4	15- 9	19- 2	9- 4	12- 4	14-11	17- 9
	Southern pine #2	9- 2	12- 1	14- 8	17- 2	8- 8	11- 3	13- 5	15- 8
	Southern pine #3	7- 4	9- 5	11- 1	13- 2	6- 9	8- 7	10- 1	12- 1
	Spruce-pine-fir SS	9- 0	11-10	15- 1	18- 4	9- 0	11-10	15- 1	17- 9
	Spruce-pine-fir #1	8- 9	11- 6	14- 1	16- 3	8- 3	10- 6	12-10	14-10
	Spruce-pine-fir #2	8- 9	11- 6	14- 1	16- 3	8- 3	10- 6	12-10	14-10
	Spruce-pine-fir #3	6-10	8- 8	10- 7	12- 4	6- 3	7-11	9- 8	11- 3
24	Douglas fir-larch SS	9- 0	11-11	15- 2	18- 5	9- 0	11-11	14- 9	17- 1
	Douglas fir-larch #1	8- 8	11- 0	13- 5	15- 7	7-11	10- 0	12- 3	14- 3
	Douglas fir-larch #2	8- 1	10- 3	12- 7	14- 7	7- 5	9- 5	11- 6	13- 4
	Douglas fir-larch #3	6- 2	7- 9	9- 6	11- 0	5- 7	7- 1	8- 8	10- 1
	Hem-fir SS	8- 6	11- 3	14- 4	17- 5	8- 6	11- 3	14- 4	16-10 ^a
	Hem-fir #1	8- 4	10- 9	13- 1	15- 2	7- 9	9- 9	11-11	13-10
	Hem-fir #2	7-11	10- 2	12- 5	14- 4	7- 4	9- 3	11- 4	13- 1
	Hem-fir #3	6- 2	7- 9	9- 6	11- 0	5- 7	7- 1	8- 8	10- 1
	Southern pine SS	8-10	11- 8	14-11	18- 1	8-10	11- 8	14-11	18- 1
	Southern pine #1	8- 8	11- 5	14- 7	17- 5	8- 8	11- 3	13- 4	15-11
	Southern pine #2	8- 6	11- 0	13- 1	15- 5	7- 9	10- 0	12- 0	14- 0
	Southern pine #3	6- 7	8- 5	9-11	11-10	6- 0	7- 8	9- 1	10- 9
	Spruce-pine-fir SS	8- 4	11- 0	14- 0	17- 0	8- 4	11- 0	13- 8	15-11
	Spruce-pine-fir #1	8- 1	10- 3	12- 7	14- 7	7- 5	9- 5	11- 6	13- 4
	Spruce-pine-fir #2	8- 1	10- 3	12- 7	14- 7	7- 5	9- 5	11- 6	13- 4
	Spruce-pine-fir #3	6- 2	7- 9	9- 6	11- 0	5- 7	7- 1	8- 8	10- 1

NOTE: Check sources for availability of lumber in lengths greater than 20 feet.
 For SI: 1 inch = 25.4 mm, 1 foot = 304.8 mm, 1 pound per square foot = 0.0479kN/m².
 a. End bearing length shall be increased to 2 inches.

TABLE R502.3.3(1)
CANTILEVER SPANS FOR FLOOR JOISTS SUPPORTING LIGHT-FRAME EXTERIOR BEARING WALL AND ROOF ONLY^{a, b, c, f, g, h}
(Floor Live Load ≤ 40 psf, Roof Live Load ≤ 20 psf)

Member & Spacing	Maximum Cantilever Span (Uplift Force at Backspan Support in Lbs.) ^{d, e}											
	Ground Snow Load											
	≤ 20 psf			30 psf			50 psf			70 psf		
	Roof Width			Roof Width			Roof Width			Roof Width		
	24 ft.	32 ft.	40 ft.	24 ft.	32 ft.	40 ft.	24 ft.	32 ft.	40 ft.	24 ft.	32 ft.	40 ft.
2 × 8 @ 12"	20" (177)	15" (227)	—	18" (209)	—	—	—	—	—	—	—	—
2 × 10 @ 16"	29" (228)	21" (297)	16" (364)	26" (271)	18" (354)	—	20" (375)	—	—	—	—	—
2 × 10 @ 12"	36" (166)	26" (219)	20" (270)	34" (198)	22" (263)	16" (324)	26" (277)	—	—	19" (356)	—	—
2 × 12 @ 16"	—	32" (287)	25" (356)	36" (263)	29" (345)	21" (428)	29" (367)	20" (484)	—	23" (471)	—	—
2 × 12 @ 12"	—	42" (209)	31" (263)	—	37" (253)	27" (317)	36" (271)	27" (358)	17" (447)	31" (348)	19" (462)	—
2 × 12 @ 8"	—	48" (136)	45" (169)	—	48" (164)	38" (206)	—	40" (233)	26" (294)	36" (230)	29" (304)	18" (379)

For SI: 1 inch = 25.4 mm, 1 pound per square foot = 0.0479 kN/m².

- a. Tabulated values are for clear-span roof supported solely by exterior bearing walls.
- b. Spans are based on No. 2 Grade lumber of Douglas fir-larch, hem-fir, southern pine, and spruce-pine-fir for repetitive (3 or more) members.
- c. Ratio of backspan to cantilever span shall be at least 3:1.
- d. Connections capable of resisting the indicated uplift force shall be provided at the backspan support.
- e. Uplift force is for a backspan to cantilever span ratio of 3:1. Tabulated uplift values are permitted to be reduced by multiplying by a factor equal to 3 divided by the actual backspan ratio provided (3/backspan ratio).
- f. See Section R301.2.2.2.2, item 1, for additional limitations on cantilevered floor joists for detached one- and two-family dwellings in Seismic Design Categories D₁ and D₂ and townhouses in Seismic Design Categories C, D₁, and D₂.
- g. A full-depth rim joist shall be provided at the cantilevered end of the joists. Solid blocking shall be provided at the cantilever support.
- h. Linear interpolation shall be permitted for building widths and ground snow loads other than shown.

TABLE R502.3.3(2)
CANTILEVER SPANS FOR FLOOR JOISTS SUPPORTING EXTERIOR BALCONY^{a, b, e, f}

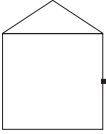
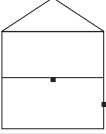
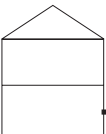
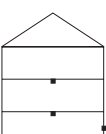
Member Size	Spacing	Maximum Cantilever Span (Uplift Force at Backspan Support in Lbs.) ^{c, d}		
		Ground Snow Load		
		≤ 30 psf	50 psf	70 psf
2 × 8	12"	42" (139)	39" (156)	34" (165)
2 × 8	16"	36" (151)	34" (171)	29" (180)
2 × 10	12"	61" (164)	57" (189)	49" (201)
2 × 10	16"	53" (180)	49" (208)	42" (220)
2 × 10	24"	43" (212)	40" (241)	34" (255)
2 × 12	16"	72" (228)	67" (260)	57" (268)
2 × 12	24"	58" (279)	54" (319)	47" (330)

For SI: 1 inch = 25.4 mm, 1 pound per square foot = 0.0479 kN/m².

- a. Spans are based on No. 2 Grade lumber of Douglas fir-larch, hem-fir, southern pine, and spruce-pine-fir for repetitive (3 or more) members.
- b. Ratio of backspan to cantilever span shall be at least 2:1.
- c. Connections capable of resisting the indicated uplift force shall be provided at the backspan support.
- d. Uplift force is for a backspan to cantilever span ratio of 2:1. Tabulated uplift values are permitted to be reduced by multiplying by a factor equal to 2 divided by the actual backspan ratio provided (2/backspan ratio).
- e. A full-depth rim joist shall be provided at the cantilevered end of the joists. Solid blocking shall be provided at the cantilevered support.
- f. Linear interpolation shall be permitted for ground snow loads other than shown.

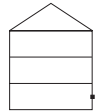
FLOORS

TABLE R502.5(1)
GIRDER SPANS^a AND HEADER SPANS^a FOR EXTERIOR BEARING WALLS
 (Maximum spans for Douglas fir-larch, hem-fir, southern pine and spruce-pine-fir^b and required number of jack studs)

GIRDERS AND HEADERS SUPPORTING	SIZE	GROUND SNOW LOAD (psf) ^e											
		30						50					
		Building width ^c (feet)											
		20		28		36		20		28		36	
Span	NJ ^d	Span	NJ ^d	Span	NJ ^d	Span	NJ ^d	Span	NJ ^d	Span	NJ ^d	Span	NJ ^d
Roof and ceiling 	2-2x4	3-6	1	3-2	1	2-10	1	3-2	1	2-9	1	2-6	1
	2-2x6	5-5	1	4-8	1	4-2	1	4-8	1	4-1	1	3-8	2
	2-2x8	6-10	1	5-11	2	5-4	2	5-11	2	5-2	2	4-7	2
	2-2x10	8-5	2	7-3	2	6-6	2	7-3	2	6-3	2	5-7	2
	2-2x12	9-9	2	8-5	2	7-6	2	8-5	2	7-3	2	6-6	2
	3-2x8	8-4	1	7-5	1	6-8	1	7-5	1	6-5	2	5-9	2
	3-2x10	10-6	1	9-1	2	8-2	2	9-1	2	7-10	2	7-0	2
	3-2x12	12-2	2	10-7	2	9-5	2	10-7	2	9-2	2	8-2	2
	4-2x8	7-0	1	6-1	2	5-5	2	6-1	2	5-3	2	4-8	2
	4-2x10	11-8	1	10-6	1	9-5	2	10-6	1	9-1	2	8-2	2
4-2x12	14-1	1	12-2	2	10-11	2	12-2	2	10-7	2	9-5	2	
Roof, ceiling and one center-bearing floor 	2-2x4	3-1	1	2-9	1	2-5	1	2-9	1	2-5	1	2-2	1
	2-2x6	4-6	1	4-0	1	3-7	2	4-1	1	3-7	2	3-3	2
	2-2x8	5-9	2	5-0	2	4-6	2	5-2	2	4-6	2	4-1	2
	2-2x10	7-0	2	6-2	2	5-6	2	6-4	2	5-6	2	5-0	2
	2-2x12	8-1	2	7-1	2	6-5	2	7-4	2	6-5	2	5-9	3
	3-2x8	7-2	1	6-3	2	5-8	2	6-5	2	5-8	2	5-1	2
	3-2x10	8-9	2	7-8	2	6-11	2	7-11	2	6-11	2	6-3	2
	3-2x12	10-2	2	8-11	2	8-0	2	9-2	2	8-0	2	7-3	2
	4-2x8	5-10	2	5-2	2	4-8	2	5-3	2	4-7	2	4-2	2
	4-2x10	10-1	1	8-10	2	8-0	2	9-1	2	8-0	2	7-2	2
4-2x12	11-9	2	10-3	2	9-3	2	10-7	2	9-3	2	8-4	2	
Roof, ceiling and one clear span floor 	2-2x4	2-8	1	2-4	1	2-1	1	2-7	1	2-3	1	2-0	1
	2-2x6	3-11	1	3-5	2	3-0	2	3-10	2	3-4	2	3-0	2
	2-2x8	5-0	2	4-4	2	3-10	2	4-10	2	4-2	2	3-9	2
	2-2x10	6-1	2	5-3	2	4-8	2	5-11	2	5-1	2	4-7	3
	2-2x12	7-1	2	6-1	3	5-5	3	6-10	2	5-11	3	5-4	3
	3-2x8	6-3	2	5-5	2	4-10	2	6-1	2	5-3	2	4-8	2
	3-2x10	7-7	2	6-7	2	5-11	2	7-5	2	6-5	2	5-9	2
	3-2x12	8-10	2	7-8	2	6-10	2	8-7	2	7-5	2	6-8	2
	4-2x8	5-1	2	4-5	2	3-11	2	4-11	2	4-3	2	3-10	2
	4-2x10	8-9	2	7-7	2	6-10	2	8-7	2	7-5	2	6-7	2
4-2x12	10-2	2	8-10	2	7-11	2	9-11	2	8-7	2	7-8	2	
Roof, ceiling and two center-bearing floors 	2-2x4	2-7	1	2-3	1	2-0	1	2-6	1	2-2	1	1-11	1
	2-2x6	3-9	2	3-3	2	2-11	2	3-8	2	3-2	2	2-10	2
	2-2x8	4-9	2	4-2	2	3-9	2	4-7	2	4-0	2	3-8	2
	2-2x10	5-9	2	5-1	2	4-7	3	5-8	2	4-11	2	4-5	3
	2-2x12	6-8	2	5-10	3	5-3	3	6-6	2	5-9	3	5-2	3
	3-2x8	5-11	2	5-2	2	4-8	2	5-9	2	5-1	2	4-7	2
	3-2x10	7-3	2	6-4	2	5-8	2	7-1	2	6-2	2	5-7	2
	3-2x12	8-5	2	7-4	2	6-7	2	8-2	2	7-2	2	6-5	3
	4-2x8	4-10	2	4-3	2	3-10	2	4-9	2	4-2	2	3-9	2
	4-2x10	8-4	2	7-4	2	6-7	2	8-2	2	7-2	2	6-5	2
4-2x12	9-8	2	8-6	2	7-8	2	9-5	2	8-3	2	7-5	2	

(continued)

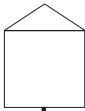
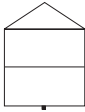
TABLE R502.5(1)—continued
GIRDER SPANS^a AND HEADER SPANS^a FOR EXTERIOR BEARING WALLS
 (Maximum spans for Douglas fir-larch, hem-fir, southern pine and spruce-pine-fir^b and required number of jack studs)

GIRDERS AND HEADERS SUPPORTING	SIZE	GROUND SNOW LOAD (psf) ^e											
		30						50					
		Building width ^c (feet)											
		20		28		36		20		28		36	
Span	NJ ^d	Span	NJ ^d	Span	NJ ^d	Span	NJ ^d	Span	NJ ^d	Span	NJ ^d	Span	NJ ^d
Roof, ceiling and two clear span floor 	2-2x4	2-1	1	1-8	1	1-6	2	2-0	1	1-8	1	1-5	2
	2-2x6	3-1	2	2-8	2	2-4	2	3-0	2	2-7	2	2-3	2
	2-2x8	3-10	2	3-4	3	3-0	3	3-10	2	3-4	2	2-11	3
	2-2x10	4-9	2	4-1	3	3-8	3	4-8	2	4-0	3	3-7	3
	2-2x12	5-6	3	4-9	3	4-3	3	5-5	3	4-8	3	4-2	3
	3-2x8	4-10	2	4-2	2	3-9	2	4-9	2	4-1	2	3-8	2
	3-2x10	5-11	2	5-1	2	4-7	3	5-10	2	5-0	2	4-6	3
	3-2x12	6-10	2	5-11	3	5-4	3	6-9	2	5-10	3	5-3	3
	4-2x8	5-7	2	4-10	2	4-4	2	5-6	2	4-9	2	4-3	2
	4-2x10	6-10	2	5-11	2	5-3	2	6-9	2	5-10	2	5-2	2
	4-2x12	7-11	2	6-10	2	6-2	3	7-9	2	6-9	2	6-0	3

For SI: 1 inch = 25.4 mm, 1 pound per square foot = 0.0479 kN/m².

- a. Spans are given in feet and inches.
- b. Tabulated values assume #2 grade lumber.
- c. Building width is measured perpendicular to the ridge. For widths between those shown, spans are permitted to be interpolated.
- d. NJ - Number of jack studs required to support each end. Where the number of required jack studs equals one, the header is permitted to be supported by an approved framing anchor attached to the full-height wall stud and to the header.
- e. Use 30 psf ground snow load for cases in which ground snow load is less than 30 psf and the roof live load is equal to or less than 20 psf.

TABLE R502.5(2)
GIRDER SPANS^a AND HEADER SPANS^a FOR INTERIOR BEARING WALLS
 (Maximum spans for Douglas fir-larch, hem-fir, southern pine and spruce-pine-fir^b and required number of jack studs)

HEADERS AND GIRDERS SUPPORTING	SIZE	BUILDING WIDTH ^c (feet)					
		20		28		36	
		Span	NJ ^d	Span	NJ ^d	Span	NJ ^d
One floor only 	2-2x4	3-1	1	2-8	1	2-5	1
	2-2x6	4-6	1	3-11	1	3-6	1
	2-2x8	5-9	1	5-0	2	4-5	2
	2-2x10	7-0	2	6-1	2	5-5	2
	2-2x12	8-1	2	7-0	2	6-3	2
	3-2x8	7-2	1	6-3	1	5-7	2
	3-2x10	8-9	1	7-7	2	6-9	2
	3-2x12	10-2	2	8-10	2	7-10	2
	4-2x8	9-0	1	7-8	1	6-9	1
	4-2x10	10-1	1	8-9	1	7-10	2
	4-2x12	11-9	1	10-2	2	9-1	2
Two floors 	2-2x4	2-2	1	1-10	1	1-7	1
	2-2x6	3-2	2	2-9	2	2-5	2
	2-2x8	4-1	2	3-6	2	3-2	2
	2-2x10	4-11	2	4-3	2	3-10	3
	2-2x12	5-9	2	5-0	3	4-5	3
	3-2x8	5-1	2	4-5	2	3-11	2
	3-2x10	6-2	2	5-4	2	4-10	2
	3-2x12	7-2	2	6-3	2	5-7	3
	4-2x8	6-1	1	5-3	2	4-8	2
	4-2x10	7-2	2	6-2	2	5-6	2
	4-2x12	8-4	2	7-2	2	6-5	2

For SI: 1 inch = 25.4 mm, 1 foot = 304.8 mm.

- a. Spans are given in feet and inches.
- b. Tabulated values assume #2 grade lumber.
- c. Building width is measured perpendicular to the ridge. For widths between those shown, spans are permitted to be interpolated.
- d. NJ - Number of jack studs required to support each end. Where the number of required jack studs equals one, the header is permitted to be supported by an approved framing anchor attached to the full-height wall stud and to the header.

FLOORS

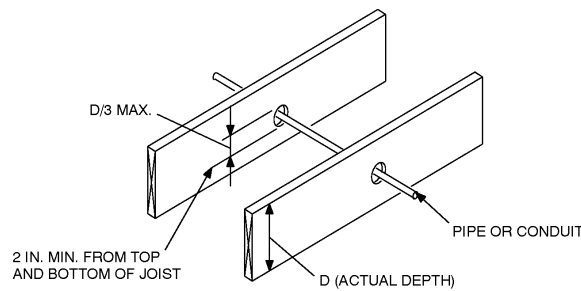
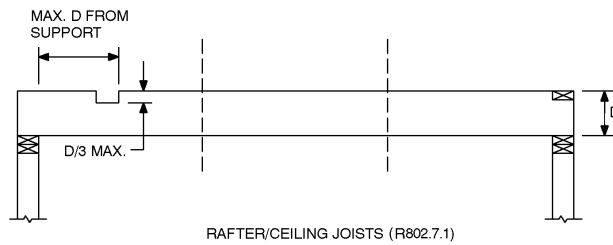
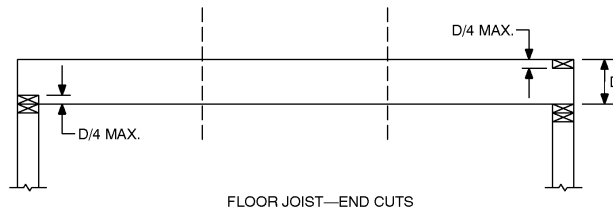
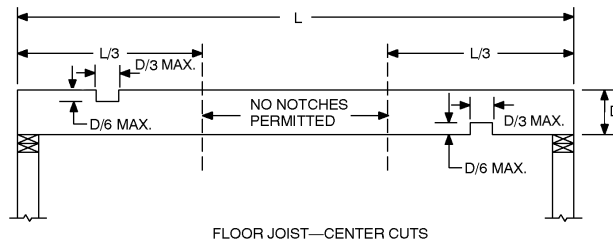
R502.6 Bearing. The ends of each joist, beam or girder shall have not less than 1.5 inches (38 mm) of bearing on wood or metal and not less than 3 inches (76 mm) on masonry or concrete except where supported on a 1-inch-by-4-inch (25.4 mm by 102 mm) ribbon strip and nailed to the adjacent stud or by the use of approved joist hangers.

R502.6.1 Floor systems. Joists framing from opposite sides over a bearing support shall lap a minimum of 3 inches (76 mm) and shall be nailed together with a minimum three

10d face nails. A wood or metal splice with strength equal to or greater than that provided by the nailed lap is permitted.

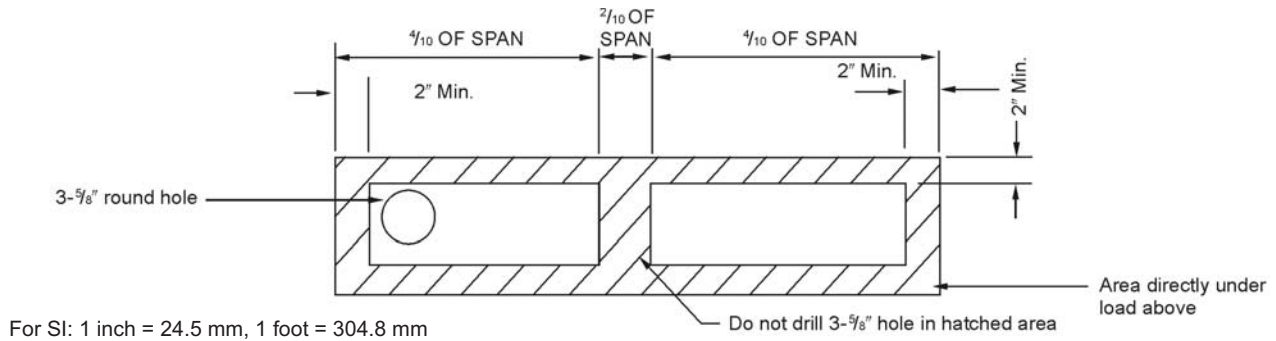
R502.6.2 Joist framing. Joists framing into the side of a wood girder shall be supported by approved framing anchors or on ledger strips not less than nominal 2 inches by 2 inches (51 mm by 51 mm).

R502.7 Lateral restraint at supports. Joists shall be supported laterally at the ends by full-depth solid blocking not less than 2 inches (51 mm) nominal in thickness; or by attachment



For SI: 1 inch = 25.4 mm.

FIGURE R502.8
CUTTING, NOTCHING AND DRILLING



1. Do not drill in center $\frac{2}{10}$'s of joist span.
2. Do not drill directly under load bearing walls at ends.
3. Do not drill closer than 2' to top or bottom edge.
4. Apply 4'-0" joist width x $\frac{1}{2}$ " CDX plywood with face grain running with joist to both sides using XX nails or 1 $\frac{1}{2}$ " screws 1" from top and bottom 4" o.c..
5. Holes shall not be closer than 2'-0" o.c. within unhatched area only.
6. Plywood shall be attached such that 2' minimum of plywood is on each side of the hole location, except when the hole is located within 2 feet of end joist

FIGURE R502.8(a)
ACCEPTABLE LOCATION OF 3 $\frac{5}{8}$ -inch DIAMETER HOLE IN 2 x 10 JOIST

to a header, band, or rim joist, or to an adjoining stud; or shall be otherwise provided with lateral support to prevent rotation.

Exception: In Seismic Design Categories D_1 and D_2 , lateral restraint shall also be provided at each intermediate support.

R502.7.1 Bridging. Joists exceeding a nominal 2 inches by 12 inches (51 mm by 305 mm) shall be supported laterally by solid blocking, diagonal bridging (wood or metal), or a continuous 1-inch-by-3-inch (25.4 mm by 76 mm) strip nailed across the bottom of joists perpendicular to joists at intervals not exceeding 8 feet (2438 mm).

R502.8 Drilling and notching. Structural floor members shall not be cut, bored or notched in excess of the limitations specified in this section. See Figure R502.8.

R502.8.1 Sawn lumber. Notches in solid lumber joists, rafters and beams shall not exceed one-sixth of the depth of the member, shall not be longer than one-third of the depth of the member and shall not be located in the middle one-third of the span. Notches at the ends of the member shall not exceed one-fourth the depth of the member. The tension side of members 4 inches (102 mm) or greater in nominal thickness shall not be notched except at the ends of the members. The diameter of holes bored or cut into members shall not exceed one-third the depth of the member. Holes shall not be closer than 2 inches (51 mm) to the top or bottom of the member, or to any other hole located in the member. Where the member is also notched, the hole shall not be closer than 2 inches (51 mm) to the notch.

R502.8.2 Engineered wood products. Cuts, notches and holes bored in trusses, laminated veneer lumber, glue-laminated members or I-joists are not permitted unless the effects of such penetrations are specifically considered in the design of the member.

R502.9 Fastening. Floor framing shall be nailed in accordance with Table R602.3(1). Where posts and beam or girder construc-

tion is used to support floor framing, positive connections shall be provided to ensure against uplift and lateral displacement.

R502.10 Framing of openings. Openings in floor framing shall be framed with a header and trimmer joists. When the header joist span does not exceed 4 feet (1219 mm), the header joist may be a single member the same size as the floor joist. Single trimmer joists may be used to carry a single header joist that is located within 3 feet (914 mm) of the trimmer joist bearing. When the header joist span exceeds 4 feet (1219 mm), the trimmer joists and the header joist shall be doubled and of sufficient cross section to support the floor joists framing into the header. Approved hangers shall be used for the header joist to trimmer joist connections when the header joist span exceeds 6 feet (1829 mm). Tail joists over 12 feet (3658 mm) long shall be supported at the header by framing anchors or on ledger strips not less than 2 inches by 2 inches (51 mm by 51 mm).

R502.11 Wood trusses.

R502.11.1 Design. Wood trusses shall be designed in accordance with approved engineering practice. The design and manufacture of metal plate connected wood trusses shall comply with ANSI/TPI 1. The truss design drawings shall be prepared by a registered professional where required by the statutes of the jurisdiction in which the project is to be constructed in accordance with Section R106.1.

R502.11.2 Bracing. Trusses shall be braced to prevent rotation and provide lateral stability in accordance with the requirements specified in the construction documents for the building and on the individual truss design drawings. In the absence of specific bracing requirements, trusses shall be braced in accordance with the TPI, HIB.

R502.11.3 Alterations to trusses. Truss members and components shall not be cut, notched, spliced or otherwise altered in any way without the approval of a registered design professional. Alterations resulting in the addition of load (e.g., HVAC equipment, water heater, etc.), that exceed the design

load for the truss, shall not be permitted without verification that the truss is capable of supporting the additional loading.

R502.11.4 Truss design drawings. Truss design drawings, prepared in compliance with Section R502.11.1, shall be provided to the building official and approved prior to installation. Truss design drawing shall be provided with the shipment of trusses delivered to the job site. Truss design drawings shall include, at a minimum, the information specified below:

1. Slope or depth, span, and spacing.
2. Location of all joints.
3. Required bearing widths.
4. Design loads as applicable.
 - 4.1. Top chord live load (including snow loads).
 - 4.2. Top chord dead load.
 - 4.3. Bottom chord live load.
 - 4.4. Bottom chord dead load.
 - 4.5. Concentrated loads and their points of application.
 - 4.6. Controlling wind and earthquake loads.
5. Adjustments to lumber and joint connector design values for conditions of use.
6. Each reaction force and direction.
7. Joint connector type and description (e.g., size, thickness or gauge); and the dimensioned location of each joint connector except where symmetrically located relative to the joint interface.
8. Lumber size, species and grade for each member.
9. Connection requirements for:
 - 9.1. Truss-to-truss girder.
 - 9.2. Truss ply-to-ply.
 - 9.3. Field splices.
10. Calculated deflection ratio and/or maximum description for live and total load.
11. Maximum axial compression forces in the truss members to enable the building designer to design the size, connections and anchorage of the permanent continuous lateral bracing. Forces shall be shown on the truss drawing or on supplemental documents.
12. Required permanent truss member bracing location.

R502.12 Draftstopping required. When there is usable space both above and below the concealed space of a floor/ceiling assembly, draftstops shall be installed so that the area of the concealed space does not exceed 1,000 square feet (92.9 m²). Draftstopping shall divide the concealed space into approximately equal areas. Where the assembly is enclosed by a floor membrane above and a ceiling membrane below draftstopping shall be provided in floor/ceiling assemblies under the following circumstances:

1. Ceiling is suspended under the floor framing.
2. Floor framing is constructed of truss-type open-web or perforated members.

R502.12.1 Materials. Draftstopping materials shall not be less than 1/2-inch (12.7 mm) gypsum board, 3/8-inch (9.5 mm) wood structural panels, 3/8-inch (9.5 mm) Type 2-M-W particleboard or other approved materials adequately supported. Draftstopping shall be installed parallel to the floor framing members unless otherwise approved by the building official. The integrity of all draftstops shall be maintained.

R502.13 Fireblocking required. Fireblocking shall be provided in wood-frame floor construction and floor-ceiling assemblies in accordance with Section R602.8.

SECTION R503 FLOOR SHEATHING

R503.1 Lumber sheathing. Maximum allowable spans for lumber used as floor sheathing shall conform to Tables R503.1, R503.2.1.1(1) and R503.2.1.1(2).

R503.1.1 End joints. End joints in lumber used as subflooring shall occur over supports unless end-matched lumber is used, in which case each piece shall bear on at least two joists. Subflooring may be omitted when joist spacing does not exceed 16 inches (406 mm) and a 1-inch (25.4 mm) nominal tongue-and-groove wood strip flooring is applied perpendicular to the joists.

**TABLE R503.1
MINIMUM THICKNESS OF LUMBER FLOOR SHEATHING**

JOIST OR BEAM SPACING (inches)	MINIMUM NET THICKNESS	
	Perpendicular to joist	Diagonal to joist
24	1 1/16	3/4
16	5/8	5/8
48 ^a	1 1/2 T & G	N/A
54 ^b		
60 ^c		

For SI: 1 inch = 25.4 mm, 1 pound per square inch = 6.895 kPa.

- a. For this support spacing, lumber sheathing shall have a minimum F_b of 675 and minimum E of 1,100,000 (see AF&PA/NDS).
- b. For this support spacing, lumber sheathing shall have a minimum F_b of 765 and minimum E of 1,400,000 (see AF&PA/NDS).
- c. For this support spacing, lumber sheathing shall have a minimum F_b of 855 and minimum E of 1,700,000 (see AF&PA/NDS).

R503.2 Wood structural panel sheathing.

R503.2.1 Identification and grade. Wood structural panel sheathing used for structural purposes shall conform to DOC PS 1, DOC PS 2 or, when manufactured in Canada, CSA 0437 or CSA 0325. All panels shall be identified by a grade mark of certificate of inspection issued by an approved agency.

R503.2.1.1 Subfloor and combined subfloor underlayment. Where used as subflooring or combination subfloor underlayment, wood structural panels shall be of one of the grades specified in Table R503.2.1.1(1). When sanded plywood is used as combination subfloor underlayment, the grade shall be as specified in Table R503.2.1.1(2).

TABLE R503.2.1.1(1)
ALLOWABLE SPANS AND LOADS FOR WOOD STRUCTURAL PANELS FOR ROOF
AND SUBFLOOR SHEATHING AND COMBINATION SUBFLOOR UNDERLAYMENT^{a,b,c}

SPAN RATING	MINIMUM NOMINAL PANEL THICKNESS (inch)	MAXIMUM SPAN (inches)		LOAD (pounds per square foot, at maximum span)		MAXIMUM SPAN (inches)
		With edge support ^d	Without edge support	Total load	Live load	
Sheathing^e		Roof^f				Subfloor^j
12/0	$\frac{5}{16}$	12	12	40	30	0
16/0	$\frac{5}{16}$	16	16	40	30	0
20/0	$\frac{5}{16}$	20	20	40	30	0
24/0	$\frac{3}{8}$	24	20 ^g	40	30	0
24/16	$\frac{7}{16}$	24	24	50	40	16
32/16	$\frac{15}{32}, \frac{1}{2}$	32	28	40	30	16 ^h
40/20	$\frac{19}{32}, \frac{5}{8}$	40	32	40	30	20 ^{h,i}
48/24	$\frac{23}{32}, \frac{3}{4}$	48	36	45	35	24
60/32	$\frac{7}{8}$	60	48	45	35	32
Underlayment, C-C plugged, single floor^e		Roof^f				Combination subfloor underlayment^k
16 o.c.	$\frac{19}{32}, \frac{5}{8}$	24	24	50	40	16 ⁱ
20 o.c.	$\frac{19}{32}, \frac{5}{8}$	32	32	40	30	20 ^j
24 o.c.	$\frac{23}{32}, \frac{3}{4}$	48	36	35	25	24
32 o.c.	$\frac{7}{8}$	48	40	50	40	32
48 o.c.	$1\frac{3}{32}, 1\frac{1}{8}$	60	48	50	40	48

For SI: 1 inch = 25.4 mm, 1 pound per square foot = 0.0479 kN/m².

- a. The allowable total loads were determined using a dead load of 10 psf. If the dead load exceeds 10 psf, then the live load shall be reduced accordingly.
- b. Panels continuous over two or more spans with long dimension perpendicular to supports. Spans shall be limited to values shown because of possible effect of concentrated loads.
- c. Applies to panels 24 inches or wider.
- d. Lumber blocking, panel edge clips (one midway between each support, except two equally spaced between supports when span is 48 inches), tongue-and-groove panel edges, or other approved type of edge support.
- e. Includes Structural 1 panels in these grades.
- f. Uniform load deflection limitation: $\frac{1}{180}$ of span under live load plus dead load, $\frac{1}{240}$ of span under live load only.
- g. Maximum span 24 inches for $\frac{15}{32}$ - and $\frac{1}{2}$ -inch panels.
- h. Maximum span 24 inches where $\frac{3}{4}$ -inch wood finish flooring is installed at right angles to joists.
- i. Maximum span 24 inches where 1.5 inches of lightweight concrete or approved cellular concrete is placed over the subfloor.
- j. Unsupported edges shall have tongue-and-groove joints or shall be supported with blocking unless minimum nominal $\frac{1}{4}$ -inch thick underlayment with end and edge joints offset at least 2 inches or 1.5 inches of lightweight concrete or approved cellular concrete is placed over the subfloor, or $\frac{3}{4}$ -inch wood finish flooring is installed at right angles to the supports. Allowable uniform live load at maximum span, based on deflection of $\frac{1}{360}$ of span, is 100 psf.
- k. Unsupported edges shall have tongue-and-groove joints or shall be supported by blocking unless nominal $\frac{1}{4}$ -inch-thick underlayment with end and edge joints offset at least 2 inches or $\frac{3}{4}$ -inch wood finish flooring is installed at right angles to the supports. Allowable uniform live load at maximum span, based on deflection of $\frac{1}{360}$ of span, is 100 psf, except panels with a span rating of 48 on center are limited to 65 psf total uniform load at maximum span.

TABLE R503.2.1.1(2)
ALLOWABLE SPANS FOR SANDED PLYWOOD
COMBINATION SUBFLOOR UNDERLAYMENT^a

IDENTIFICATION	SPACING OF JOISTS (inches)		
	16	20	24
Species group ^b	—	—	—
1	1/2	5/8	3/4
2, 3	5/8	3/4	7/8
4	3/4	7/8	1

For SI: 1 inch = 25.4 mm, 1 pound per square foot = 0.0479 kN/m².

- a. Plywood continuous over two or more spans and face grain perpendicular to supports. Unsupported edges shall be tongue-and-groove or blocked except where nominal 1/4-inch-thick underlayment or 3/4-inch wood finish floor is used. Allowable uniform live load at maximum span based on deflection of 1/360 of span is 100 psf.
- b. Applicable to all grades of sanded exterior-type plywood.

R503.2.2 Allowable spans. The maximum allowable span for wood structural panels used as subfloor or combination subfloor underlayment shall be as set forth in Table R503.2.1.1(1). The maximum span for sanded plywood combination subfloor underlayment shall be as set forth in Table R503.2.1.1(2).

R503.2.3 Installation. Wood structural panels used as subfloor or combination subfloor underlayment shall be attached to wood framing in accordance with Table R602.3(1) and shall be attached to cold-formed steel framing in accordance with Table R505.3.1(2).

R503.3 Particleboard.

R503.3.1 Identification and grade. Particleboard shall conform to ANSI A208.1 and shall be so identified by a grade mark or certificate of inspection issued by an approved agency.

R503.3.2 Floor underlayment. Particleboard floor underlayment shall conform to Type PBU and shall not be less than 1/4 inch (6.4 mm) in thickness.

R503.3.3 Installation. Particleboard underlayment shall be installed in accordance with the recommendations of the manufacturer and attached to framing in accordance with Table R602.3(1).

SECTION R504
PRESSURE PRESERVATIVELY TREATED-WOOD
FLOORS (ON GROUND)

R504.1 General. Pressure preservatively treated-wood basement floors and floors on ground shall be designed to withstand axial forces and bending moments resulting from lateral soil pressures at the base of the exterior walls and floor live and dead loads. Floor framing shall be designed to meet joist deflection requirements in accordance with Section R301.

R504.1.1 Unbalanced soil loads. Unless special provision is made to resist sliding caused by unbalanced lateral soil loads, wood basement floors shall be limited to applications where the differential depth of fill on opposite exterior foundation walls is 2 feet (610 mm) or less.

R504.1.2 Construction. Joists in wood basement floors shall bear tightly against the narrow face of studs in the foundation wall or directly against a band joist that bears on the studs. Plywood subfloor shall be continuous over lapped joists or over butt joints between in-line joists. Sufficient blocking shall be provided between joists to transfer lateral forces at the base of the end walls into the floor system.

R504.1.3 Uplift and buckling. Where required, resistance to uplift or restraint against buckling shall be provided by interior bearing walls or properly designed stub walls anchored in the supporting soil below.

R504.2 Site preparation. The area within the foundation walls shall have all vegetation, topsoil and foreign material removed, and any fill material that is added shall be free of vegetation and foreign material. The fill shall be compacted to assure uniform support of the pressure preservatively treated-wood floor sleepers.

R504.2.1 Base. A minimum 4-inch-thick (102 mm) granular base of gravel having a maximum size of 3/4 inch (19.1 mm) or crushed stone having a maximum size of 1/2 inch (12.7 mm) shall be placed over the compacted earth.

R504.2.2 Moisture barrier. Polyethylene sheeting of minimum 6-mil (0.15 mm) thickness shall be placed over the granular base. Joints shall be lapped 6 inches (152 mm) and left unsealed. The polyethylene membrane shall be placed over the pressure preservatively treated-wood sleepers and shall not extend beneath the footing plates of the exterior walls.

R504.3 Materials. All framing materials, including sleepers, joists, blocking and plywood subflooring, shall be pressure preservatively treated and dried after treatment in accordance with AWPA C22.

SECTION R505
STEEL FLOOR FRAMING

R505.1 Cold-formed steel floor framing. Elements shall be straight and free of any defects that would significantly affect structural performance. Cold-formed steel floor framing members shall comply with the requirements of this section.

R505.1.1 Applicability limits. The provisions of this section shall control the construction of steel floor framing for buildings not greater than 60 feet (18 288 mm) in length perpendicular to the joist span, not greater than 36 feet (10 973 mm) in width parallel to the joist span, and not greater than two stories in height with each story not greater than 10 feet (3048 mm) high. Steel floor framing constructed in accordance with the provisions of this section shall be limited to sites subjected to a maximum design wind speed of 110 miles per hour Exposure A, B or C and a maximum ground snow load of 70 pounds per square foot (3.35 kN/m²).

R505.1.2 In-line framing. When supported by steel-framed walls in accordance with Section R603, steel floor framing shall be constructed with floor joists located directly in-line with load-bearing studs located below the joists with a maximum tolerance of 3/4 inch (19.1 mm) between the center lines of the joist and the stud.

R505.2 Structural framing. Load-bearing floor framing members shall comply with Figure R505.2(1) and with the dimen-

**TABLE R505.2(1)
COLD-FORMED STEEL JOIST SIZES**

MEMBER DESIGNATION ^a	WEB DEPTH (inches)	MINIMUM FLANGE WIDTH (inches)	MAXIMUM FLANGE WIDTH (inches)	MINIMUM LIP SIZE (inches)
550S162-t	5.5	1.625	2	0.5
800S162-t	8	1.625	2	0.5
1000S162-t	10	1.625	2	0.5
1200S162-t	12	1.625	2	0.5

For SI: 1 inch = 25.4 mm.

a. The member designation is defined by the first number representing the member depth in 1/100 inches, the letter "S" representing a stud or joist member, the second number representing the flange width in 1/100 inches, and the letter "t" shall be a number representing the minimum base metal thickness in mils [See Table R505.2(2)].

sional and minimum thickness requirements specified in Tables R505.2(1) and R505.2(2). Tracks shall comply with Figure R505.2(2) and shall have a minimum flange width of 1 1/4 inches (32 mm). The maximum inside bend radius for members shall be the greater of 3/32 inch (2.4 mm) or twice the uncoated steel thickness. Holes in joist webs shall conform to Figure R505.2(3) and to the dimensional requirements specified in Table R505.2(3). Holes shall be permitted only along the centerline of the web of the framing member. Holes for 800S162-33, 1000S162-43, 1200S162-43 and 1200S162-54 nominal joist sizes located less than 10 inches (254 mm) from the edge of load-bearing surface shall be patched in accordance with Section R505.3.6.

R505.2.1 Material. Load-bearing members utilized in steel floor construction shall be cold formed to shape from structural quality sheet steel complying with the requirements of one of the following:

1. ASTM A 653: Grades 33, 37, 40 and 50 (Class 1 and 3).
2. ASTM A 792: Grades 33, 37, 40 and 50A.
3. ASTM A 875: Grades 33, 37, 40 and 50 (Class 1 and 3).
4. Steels that comply with ASTM A 653, except for tensile and elongation, shall be permitted provided the ratio of tensile strength to yield point is at least 1.08 and the total elongation is at least 10 percent for a 2-inch (51 mm) gage length or 7 percent for an 8-inch (203 mm) gage length.

R505.2.2 Identification. Load-bearing steel framing members shall have a legible label, stencil, stamp or embossment with the following information as a minimum:

1. Manufacturer's identification.
2. Minimum uncoated steel thickness in inches (mm).

3. Minimum coating designation.
4. Minimum yield strength, in kips per square inch (ksi) (kPa).

R505.2.3 Corrosion protection. Load-bearing steel framing shall have a metallic coating complying with one of the following:

1. A minimum of G 60 in accordance with ASTM A 653.
2. A minimum of AZ 50 in accordance with ASTM A 792.
3. A minimum of GF 60 in accordance with ASTM A 875.

R505.2.4 Fastening requirements. Screws for steel-to-steel connections shall be installed with a minimum edge distance and center-to-center spacing of 0.5 inch (12.7 mm), shall be self-drilling tapping, and shall conform to SAE J78. Floor sheathing shall be attached to steel joists with minimum No. 8 self-drilling tapping screws that conform to SAE J78. Screws attaching floor-sheathing-to-steel joists shall have a minimum head diameter of 0.292 inch (7.4 mm) with countersunk heads and shall be installed with a minimum edge distance of 0.375 inch (9.5 mm). Gypsum board ceilings shall be attached to steel joists with minimum No. 6 screws conforming to ASTM C 954 and shall be installed in accordance with Section R702. For all connections, screws shall extend through the steel a minimum of three exposed threads. All self-drilling tapping screws conforming to SAE J78 shall have a Type II coating in accordance with ASTM B 633.

Where No. 8 screws are specified in a steel to steel connection the required number of screws in the connection is

**TABLE R505.2(2)
MINIMUM THICKNESS OF COLD-FORMED STEEL MEMBERS**

DESIGNATION (mils)	MINIMUM UNCOATED THICKNESS (inches)	REFERENCE GAGE NUMBER
33	0.033	20
43	0.043	18
54	0.054	16
68	0.068	14

For SI: 1 inch = 25.4 mm, 1 mil = 0.0254 mm.

TABLE R505.2(3)
MAXIMUM HOLE DIMENSIONS AND SPACING IN JOIST WEBS

NOMINAL MEMBER SIZE	MAXIMUM HOLE DEPTH ^a (inches)	MAXIMUM HOLE LENGTH ^b (inches)	MINIMUM HOLE SPACING (inches)	MINIMUM HOLE EDGE DISTANCE ^c (inches)
550S162-33	2	5.25	16.5	10
550S162-43	2	5.25	16.5	10
550S162-54	2	5.25	16.5	10
550S162-68	2	5.25	16.5	10
800S162-33	1.5	4	24	10
800S162-43	3	6	24	10
800S162-54	3	6	24	10
800S162-68	3	6	24	10
1000S162-43	1.5	4	24	10
1000S162-54	4	6	24	10
1000S162-68	4	6	24	10
1200S162-43	1.5	4	24	10
1200S162-54	1.5	4	24	10
1200S162-68	4.75	6	24	10

For SI: 1 inch = 25.4 mm.

- a. The dimension of the hole measured across the depth of the joist web
- b. The dimension of the hole measured along the length of the joist.
- c. Edge distance is measured from the edge of the hole to the edge of bearing support.

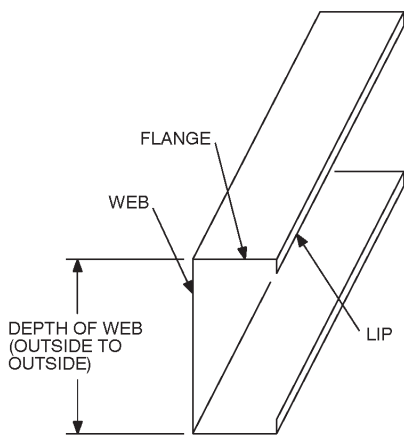


FIGURE R505.2(1)
C-SECTION

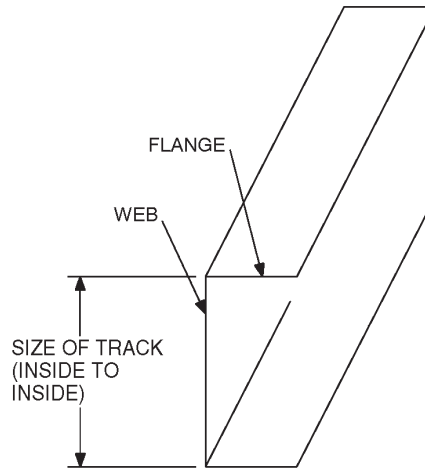


FIGURE R505.2(2)
TRACK SECTION

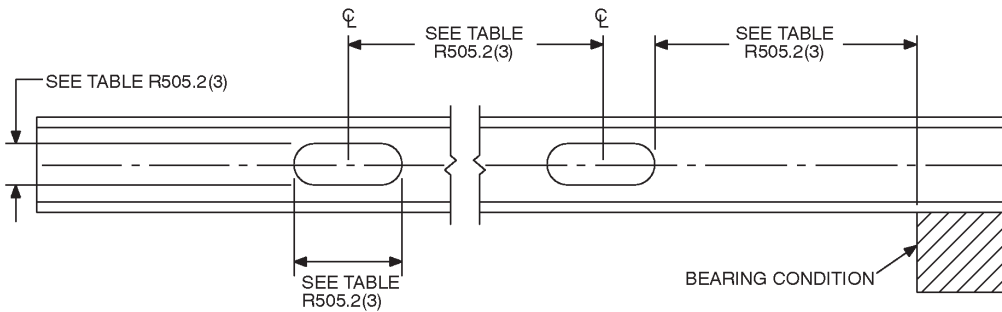


FIGURE R505.2(3)
FLOOR JOIST WEB HOLES

For SI: 1 inch = 25.4 mm.

permitted to be reduced in accordance with the reduction factors in Table R505.2.4 when larger screws are used or when one of the sheets of steel being connected is thicker than 33 mils (0.84 mm). When applying the reduction factor the resulting number of screws shall be rounded up.

**TABLE R505.2.4
SCREW SUBSTITUTION FACTOR**

SCREW SIZE	THINNEST CONNECTED STEEL SHEET (mils)	
	33	43
#8	1.0	0.67
#10	0.93	0.62
#12	0.86	0.56

For SI: 1 mil = 0.0254 mm.

R505.3 Floor construction. Cold-formed steel floors shall be constructed in accordance with this section and Figure R505.3.

R505.3.1 Floor to foundation or bearing wall connections. Cold-formed steel floors shall be anchored to foundations, wood sills or load-bearing walls in accordance with Table R505.3.1(1) and Figure R505.3.1(1), R505.3.1(2), R505.3.1(3), R505.3.1(4), R505.3.1(5) or R505.3.1(6). Continuous steel joists supported by interior load-bearing walls shall be constructed in accordance with Figure R505.3.1(7). Lapped steel joists shall be constructed in accordance with Figure R505.3.1(8). Fastening of steel joists to other framing members shall be in accordance with Table R505.3.1(2).

R505.3.2 Allowable joist spans. The clear span of cold-formed steel floor joists shall not exceed the limits set forth in Table R505.3.2. Floor joists shall have a minimum bearing length of 1.5 inches (38 mm). When continuous joists are used the interior bearing supports shall be located within 2 feet (610 mm) of mid span of the steel joists, and the individual spans shall not exceed the spans in Table R505.3.2. Bearing stiffeners shall be installed at each bearing location in accordance with Section R505.3.4 and as shown in Figure R505.3.

R505.3.3 Joist bracing. The top flanges of steel joists shall be laterally braced by the application of floor sheathing fastened to the joists in accordance with Table R505.3.1(2). Floor joists with spans that exceed 12 feet (3658 mm) shall have the bottom flanges laterally braced in accordance with one of the following:

1. Gypsum board installed with minimum No. 6 screws in accordance with Section R702.
2. Continuous steel strapping installed in accordance with Figure R505.3. Steel straps shall be at least 1.5 inches (38 mm) in width and 33 mils (0.84 mm) in thickness. Straps shall be fastened to the bottom flange at each joist with at least one No. 8 screw and shall be fastened to blocking with at least two No. 8 screws. Blocking or bridging (X-bracing) shall be installed between joists in-line with straps at a maximum spacing of 12 feet (3658 mm) measured perpendicular to the joist run and at the termination of all straps.

R505.3.4 Bearing stiffeners. Bearing stiffeners shall be installed at all bearing locations for steel floor joists. A bearing stiffener shall be fabricated from a minimum 33 mil (0.84 mm) C-section or 43 mil (1.09 mm) track section. Each stiffener shall be fastened to the web of the joist with a minimum of four No. 8 screws equally spaced as shown in Figure R505.3.4. Stiffeners shall extend across the full depth of the web and shall be installed on either side of the web.

R505.3.5 Cutting and notching. Flanges and lips of load-bearing steel floor framing members shall not be cut or notched.

R505.3.6 Hole patching. Web holes for 800S162-33, 1000S162-43, 1200S162-43 and 1200S162-54 nominal joist sizes with dimensions conforming to Section R505.2 that are closer than 10 inches (305 mm) from the edge of the hole to the edge of the bearing surface shall be patched with a solid steel plate, C-section or track section in accordance with Figure R505.3.6. The steel patch shall be of a minimum thickness as the receiving member and shall extend at least 1 inch (25.4 mm) beyond all edges of the hole. The steel patch shall be fastened to the web with No. 8 screws (minimum) spaced no greater than 1 inch (25.4 mm) center-to-center along the edges of the patch, with a minimum edge distance of 0.5 inch (12.7 mm).

R505.3.7 Floor cantilevers. Floor cantilevers shall not exceed 24 inches (610 mm) as illustrated in Figure R505.3. The cantilever back-span shall extend a minimum of 6 feet (1830 mm) within the building, and shall be fastened to a bearing condition in accordance with Section R505.3.1. Floor cantilevers shall be permitted only on the second floor of a two-story building or the first floor of a one-story building. Floor framing that is cantilevered and supports the cantilevered floor only shall consist of single joist members in accordance with Section R505.3.2. Floor framing that is cantilevered and supports the cantilevered floor and the roof framing load above shall consist of double joist members of the same size and material thickness as that for single joist members in accordance with Section R505.3.2, and shall be fastened web-to-web with minimum No. 8 screws at 24 inches (610 mm) maximum on-center spacing top and bottom. Built-up floor framing consisting of a C-section inside a track section, fastened at the top and bottom flanges by minimum No. 8 screws at 24 inches (610 mm) maximum on center spacing, is permitted in lieu of the web-to-web double joist method.

R505.3.8 Splicing. Joists and other structural members shall not be spliced. Splicing of tracks shall conform with Figure R505.3.8.

R505.3.9 Framing of openings. Openings in floor framing shall be framed with header and trimmer joists. Header joist spans shall not exceed 8 feet (2438 mm). Header and trimmer joists shall be fabricated from joist and track sections, which shall be of a minimum size and thickness as the adjacent floor joists and shall be installed in accordance with Figure R505.3. Each header joist shall be connected to trimmer joists with a minimum of four 2-inch-by-2-inch (51 mm by 51 mm) clip angles. Each clip angle shall be fastened to

FLOORS

both the header and trimmer joists with four No. 8 screws, evenly spaced, through each leg of the clip angle. The clip angles shall have a steel thickness not less than that of the floor joist.

SECTION R506 CONCRETE FLOORS (ON GROUND)

R506.1 General. Concrete slab-on-ground floors shall be a minimum 3.5 inches (89 mm) thick (for expansive soils, see Section R403.1.8). The specified compressive strength of concrete shall be as set forth in Section R402.2.

R506.2 Site preparation. The area within the foundation walls shall have all vegetation, top soil and foreign material removed.

R506.2.1 Fill. Fill material shall be free of vegetation and foreign material. The fill shall be compacted to assure uniform support of the slab, and except where approved, the fill depths shall not exceed 24 inches (610 mm) for clean sand or gravel and 8 inches (203 mm) for earth.

R506.2.2 Base. A 4-inch-thick (102 mm) base course consisting of clean graded sand, gravel, crushed stone or

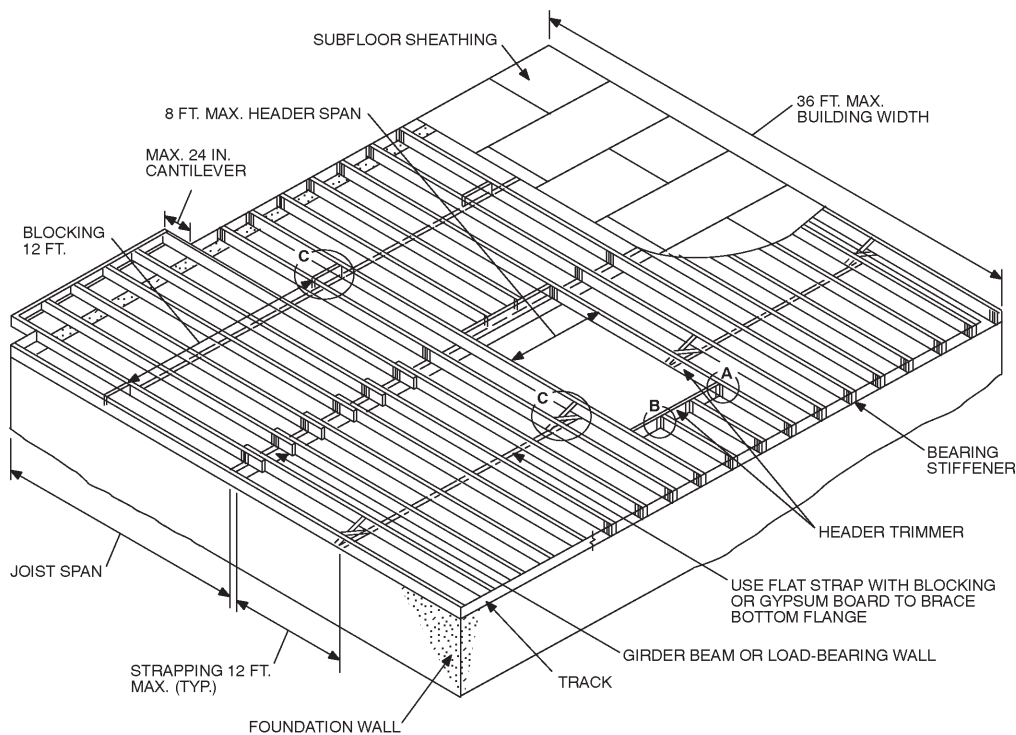
crushed blast-furnace slag passing a 2-inch (51 mm) sieve shall be placed on the prepared subgrade when the slab is below grade.

Exception: A base course is not required when the concrete slab is installed on well-drained or sand-gravel mixture soils classified as Group I according to the United Soil Classification System in accordance with Table R405.1.

R506.2.3 Vapor retarder. A 6 mil (0.006 inch; 152 μ m) polyethylene or approved vapor retarder with joints lapped not less than 6 inches (152 mm) shall be placed between the concrete floor slab and the base course or the prepared subgrade where no base course exists.

Exception: The vapor retarder may be omitted:

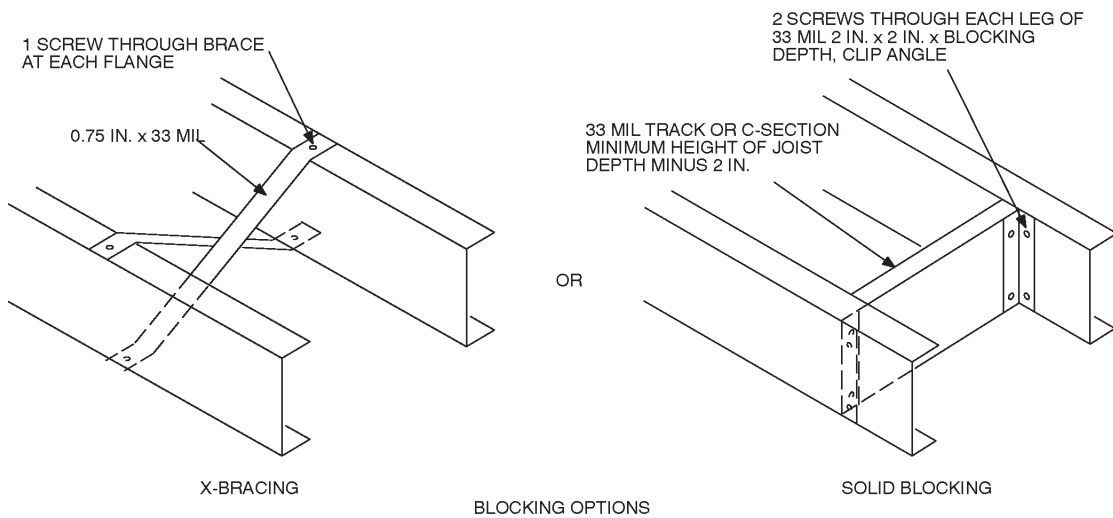
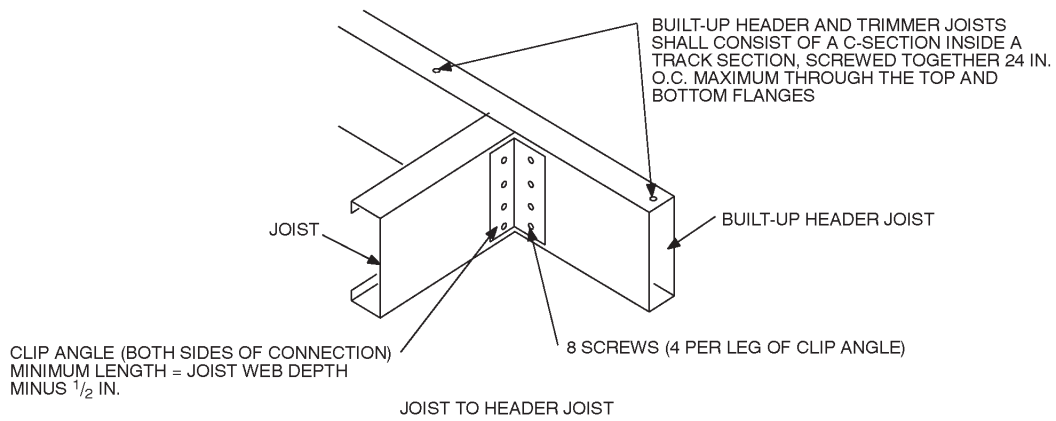
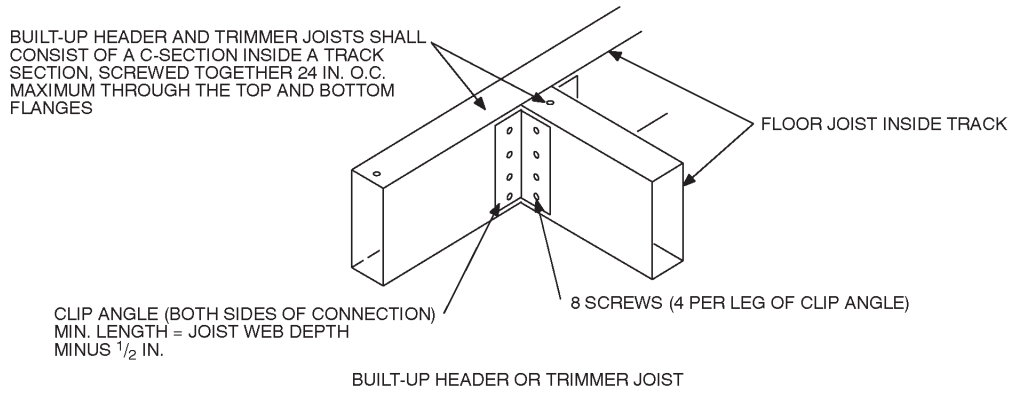
1. From garages, utility buildings and other unheated accessory structures.
2. From driveways, walks, patios and other flatwork not likely to be enclosed and heated at a later date.
3. Where approved by the building official, based on local site conditions.



For SI: 1 inch = 25.4 mm, 1 foot = 304.8 mm.

**FIGURE R505.3
STEEL FLOOR CONSTRUCTION**

(continued)



For SI: 1 inch = 25.4 mm, 1 mil = 0.0254 mm.

FIGURE R505.3—continued
STEEL FLOOR CONSTRUCTION

FLOORS

**TABLE R505.3.1(1)
FLOOR TO FOUNDATION OR BEARING WALL CONNECTION REQUIREMENTS ^{a,b}**

FRAMING CONDITION	WIND SPEED (mph) AND EXPOSURE	
	Up to 110 A/B or 85 C or Seismic Design Categories A, B, C	Up to 110 C
Floor joist to wall track of exterior steel load-bearing wall per Figure R505.3.1(1)	2-No. 8 screws	3-No. 8 screws
Floor joist track to wood sill per Figure R505.3.1(2)	Steel plate spaced at 3' o.c., with 4-No. 8 screws and 4-10d or 6-8d common nails	Steel plate, spaced at 2' o.c., with 4-No. 8 screws and 4-10d or 6-8d common nails
Floor joist track to foundation per Figure R505.3.1(3)	1/2" minimum diameter anchor bolt and clip angle spaced at 6' o.c. with 8-No. 8 screws	1/2" minimum diameter anchor bolt and clip angle spaced at 4' o.c. with 8-No. 8 screws
Joist cantilever to wall track per Figure R505.3.1(4)	2-No. 8 screws per stiffener or bent plate	3-No. 8 screws per stiffener or bent plate
Joist cantilever to wood sill per Figure R505.3.1(5)	Steel plate spaced at 3' o.c., with 4-No. 8 screws and 4-10d or 6-8d common nails	Steel plate spaced at 2' o.c., with 4-No. 8 screws and 4-10d or 6-8d common nails
Joist cantilever to foundation per Figure R505.3.1(6)	1/2" minimum diameter anchor bolt and clip angle spaced at 6' o.c. with 8-No. 8 screws	1/2" minimum diameter anchor bolt and clip angle spaced at 4' o.c. with 8-No. 8 screws

For SI: 1 inch = 25.4 mm, 1 foot = 304.8 mm, 1 mile per hour = 1.609 km/h.

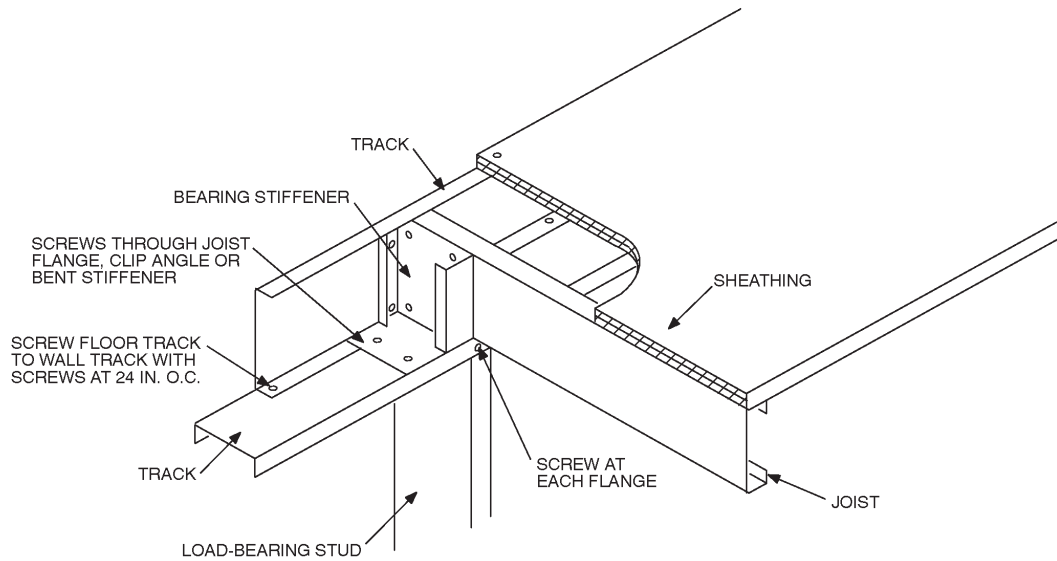
- a. Anchor bolts shall be located not more than 12 inches from corners or the termination of bottom tracks (e.g., at door openings). Bolts shall extend a minimum of 15 inches into masonry or 7 inches into concrete.
- b. All screw sizes shown are minimum.

**TABLE R505.3.1(2)
FLOOR FASTENING SCHEDULE^a**

DESCRIPTION OF BUILDING ELEMENTS	NUMBER AND SIZE OF FASTENERS	SPACING OF FASTENERS
Floor joist to track of an interior load-bearing wall per Figures R505.3.1(7) and R505.3.1(8)	2 No. 8 screws	Each joist
Floor joist to track at end of joist	2 No. 8 screws	One per flange or two per bearing stiffener
Subfloor to floor joists	No. 8 screws	6" o.c. on edges and 10" o.c. at intermediate supports

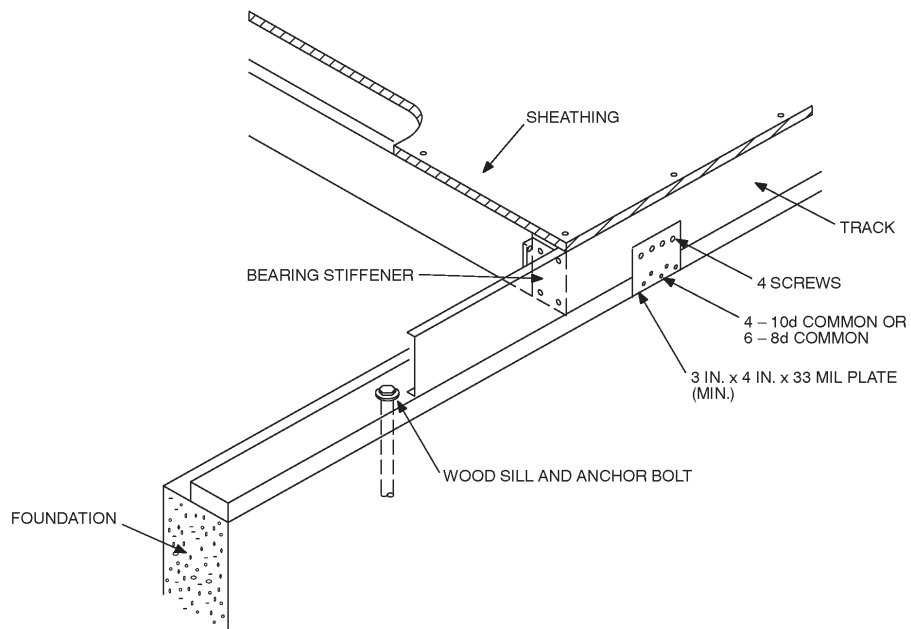
For SI: 1 inch = 25.4 mm.

- a. All screw sizes shown are minimum.



For SI: 1 inch = 25.4 mm, 1 mil = 0.0254 mm.

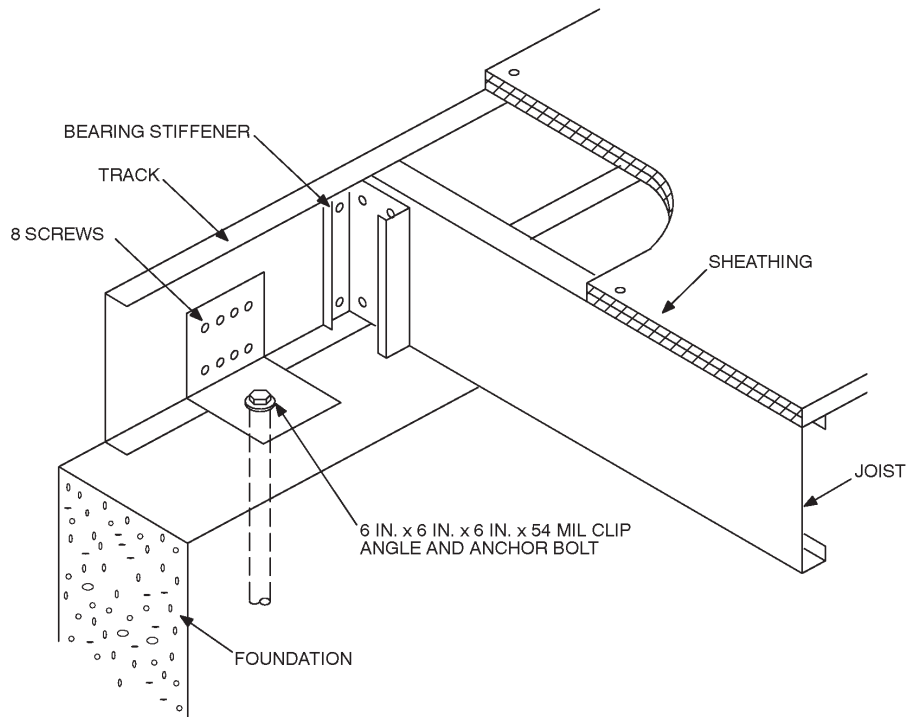
FIGURE R505.3.1(1)
FLOOR TO LOAD-BEARING WALL STUD CONNECTION



For SI: 1 inch = 25.4 mm, 1 mil = 0.0254 mm.

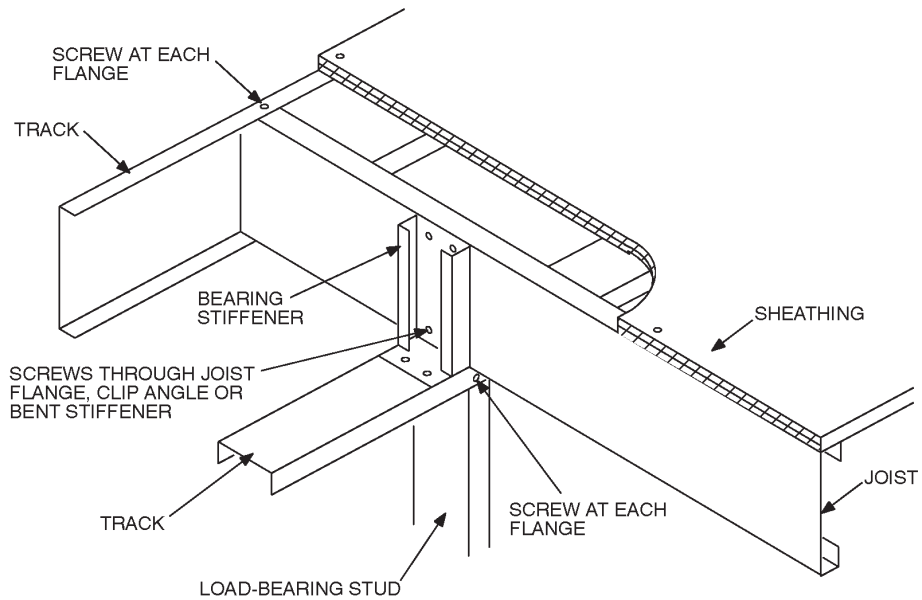
FIGURE R505.3.1(2)
FLOOR TO WOOD SILL CONNECTION

FLOORS

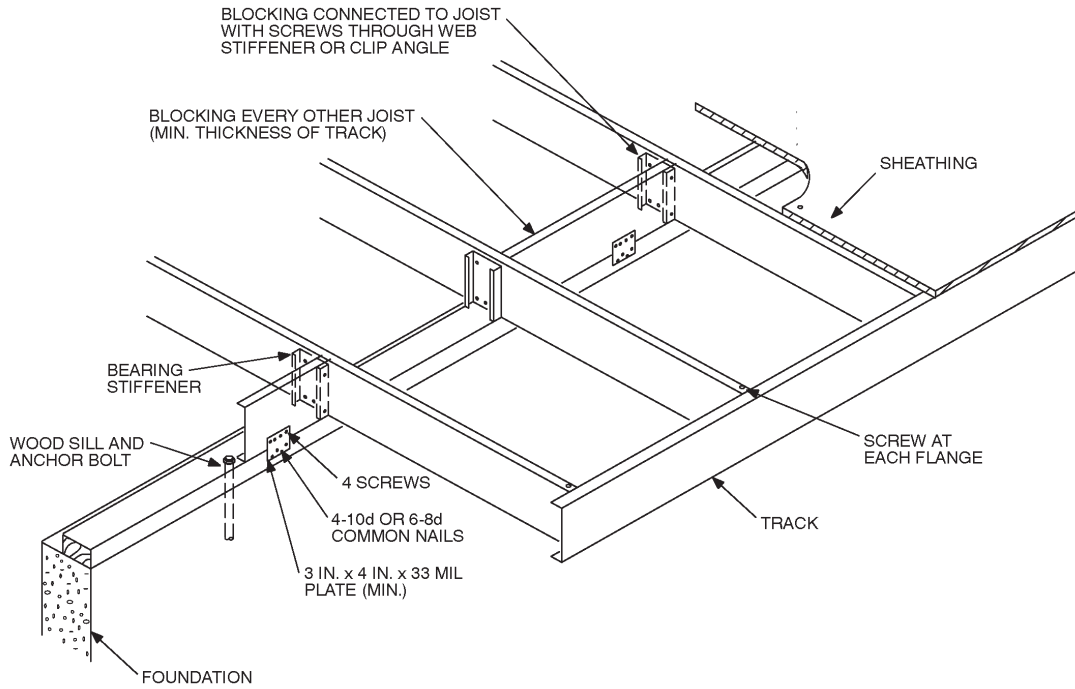


For SI: 1 inch = 25.4 mm, 1 mil = 0.0254 mm.

**FIGURE R505.3.1(3)
FLOOR TO FOUNDATION CONNECTION**

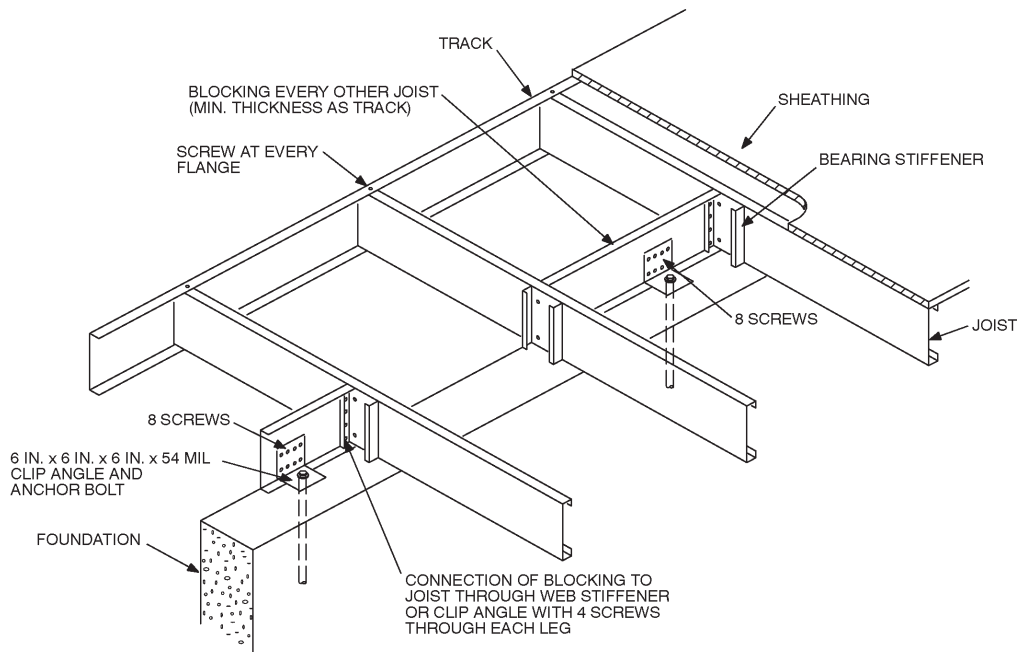


**FIGURE R505.3.1(4)
FLOOR CANTILEVER TO LOAD-BEARING WALL CONNECTION**



For SI: 1 inch = 25.4 mm, 1 mil = 0.0254 mm.

FIGURE R505.3.1(5)
FLOOR CANTILEVER TO WOOD SILL CONNECTION



For SI: 1 inch = 25.4 mm, 1 mil = 0.0254 mm.

FIGURE R505.3.1(6)
FLOOR CANTILEVER TO FOUNDATION CONNECTION

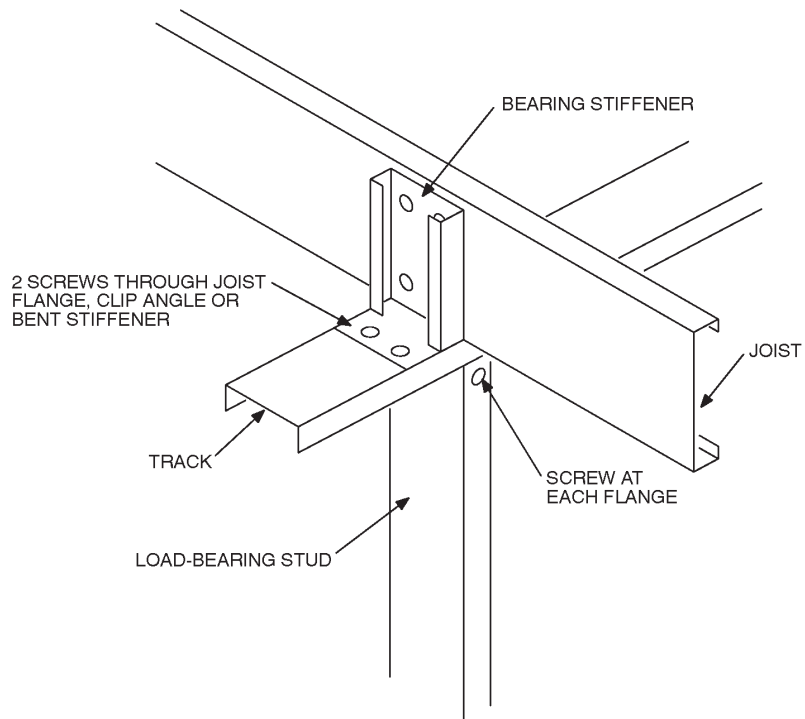


FIGURE R505.3.1(7)
CONTINUOUS JOIST SPAN SUPPORTED ON STUD

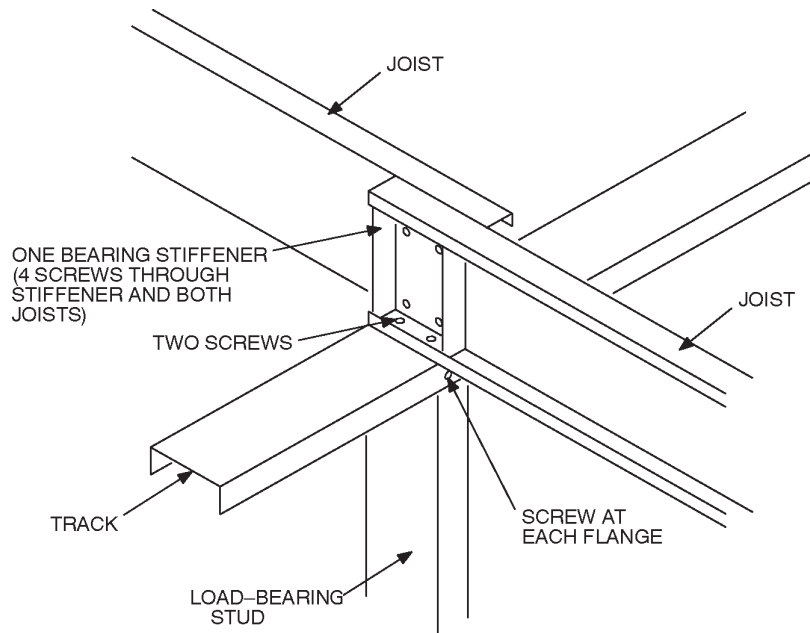


FIGURE R505.3.1(8)
LAPPED JOISTS SUPPORTED ON STUD

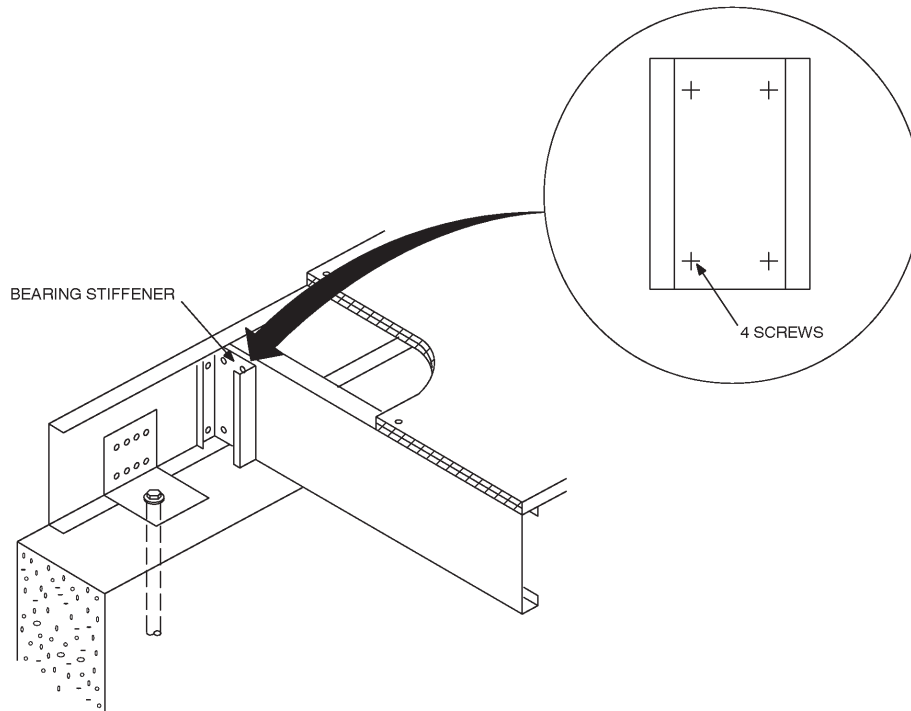
**TABLE R505.3.2
ALLOWABLE SPANS FOR COLD-FORMED STEEL JOISTS^{a,b}**

NOMINAL JOIST SIZE	30 PSF LIVE LOAD		40 PSF LIVE LOAD	
	Spacing (inches)		Spacing (inches)	
	16	24	16	24
550S162-33	10'-7"	9'-1"	9'-7"	8'-1"
550S162-43	11'-6"	10'-0"	10'-5"	9'-1"
550S162-54	12'-4"	10'-9"	11'-2"	9'-9"
550S162-68	13'-2"	11'-6"	12'-0"	10'-6"
800S162-33	13'-3"	8'-10"	10'-7"	7'-1"
800S162-43	15'-6"	13'-7"	14'-1"	12'-3"
800S162-54	16'-8"	14'-7"	15'-2"	13'-3"
800S162-68	17'-11"	15'-7"	16'-3"	14'-2"
1000S162-43	18'-8"	15'-3"	16'-8"	13'-1"
1000S162-54	20'-1"	17'-6"	18'-3"	15'-11"
1000S162-68	21'-6"	18'-10"	19'-7"	17'-1"
1200S162-43	20'-3"	14'-1"	16'-10"	11'-3"
1200S162-54	23'-4"	19'-7"	21'-3"	17'-6"
1200S162-68	25'-1"	21'-11"	22'-10"	19'-11"

For SI: 1 inch = 25.4 mm, 1 foot = 304.8 mm, 1 pound per square foot = 0.0479kN/m².

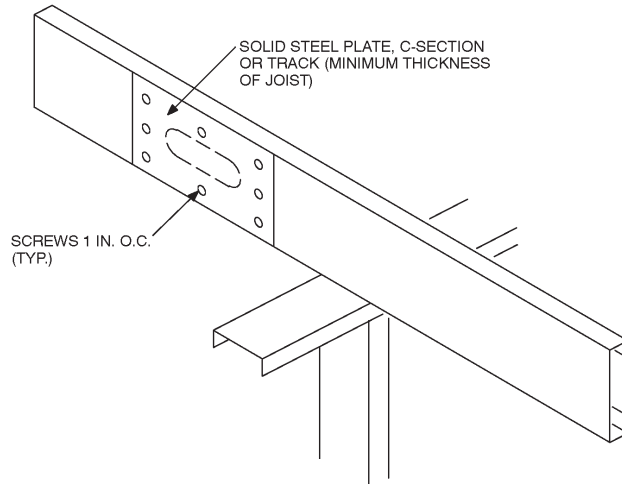
a. Deflection criteria: $L/480$ for live loads, $L/360$ for total loads.

b. Floor dead load = 10 psf.



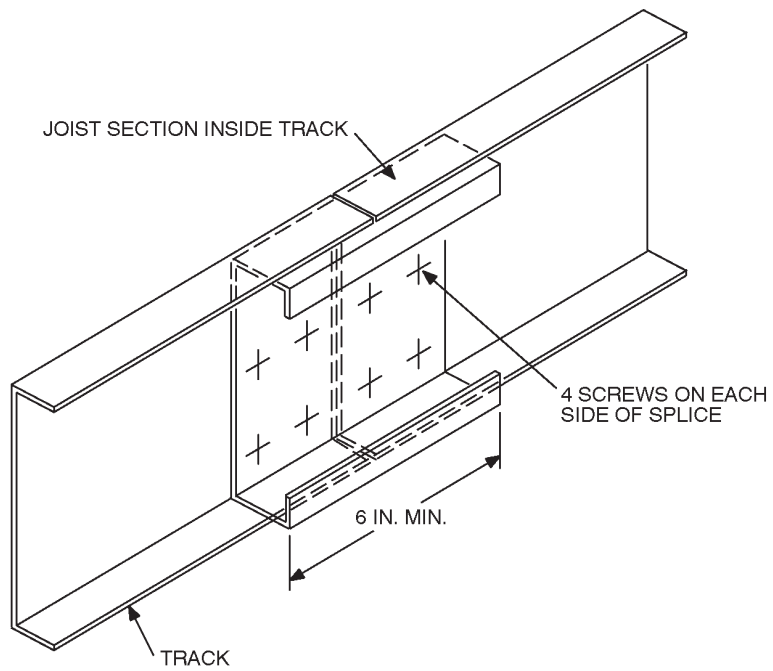
**FIGURE R505.3.4
BEARING STIFFENER**

FLOORS



For SI: 1 inch = 25.4 mm.

**FIGURE R505.3.6
HOLE PATCH**



For SI: 1 inch = 25.4 mm.

**FIGURE R505.3.8
TRACK SPLICE**